



QUADROLEGNO®

QUADROLEGNO

PATTERNS

# Sommario Summary

1  
2

1.

2.

Prefazione al Catalogo / Preface to the catalogue

Classicismo Passato / Past Classicism

3. Confrontare
4. Interpretare
5. Invitare
6. Esultare
7. Esplorare
8. Immaginare
9. Incastrare

10  
13

10.

13.

Tetrissando / Playing Tetris

11. Collegare
12. Raggruppare

Tassellature Artistiche / Artistic Tassellation

14. Accogliere
15. Avvolgere
16. Conoscere

17  
21

17.

21.

Algoritmicamente / Algorithmically

18. Ideare
19. Attrarre
20. Attirare

Geometrie Lignee / Wooden Geometries

22. Regina / Sole / Lucina
23. Giove / Minerva / Marte
24. Venere / Cupido / Giunone
25. Mercurio / Diana / Luna

# Prefazione al Catalogo

## Preface to the Catalogue

I Patterns QuadroLegno nascono dal profondo desiderio di unire le composizioni geometriche passate a una materia nobile e splendidamente versatile e naturale come il legno. Un binomio ricco di fascino, di storia, di cultura che arricchisce trasversalmente ambienti di qualsiasi tipologia rendendo "ieri" attuale ed aprendo un futuro non scritto, ma tutto da scrivere lungo un percorso, un cammino ricco di sfide e senza limiti.

Strumento potente a disposizione di tutti coloro che vogliono con il cuore oltre che con la mente, lasciare qualcosa, fare qualcosa di nuovo nell'ambito dei pavimenti in legno esplorando contesti scientifici come la geometria, conoscenza marginalmente utilizzata nel campo delle superfici in legno. La mancanza di limiti disorienta, spaventa, ma affascina perché ci rende liberi di esprimere ciò che sentiamo ora coscienti che sarà diverso da quello che sentiremo domani e nulla è più eccitante di un pensiero dinamico che è la nostra evoluzione professionale e personale.

The QuadroLegno Patterns arise from the deep desire to combine past geometric compositions with a noble, beautifully versatile and natural material as wood.

A fascinating duo of history and culture that enriches crosswise all types of settings, making "yesterday" a living matter and opening a future still unwritten. A future to be created along the way, a journey full of challenges and limitless.

Powerful tool available to anyone who wants, with their heart as well as their mind, to leave something, to do something new in the field of wooden floors, exploring scientific contexts as geometry, knowledge marginally used in the field of wooden surfaces.

The lack of limits is baffling, frightening but fascinating. This is because it frees us to express what we feel now, aware it will be different from what we will feel tomorrow. Nothing is more exciting than a dynamic thought, which is our professional and personal development.



# Classicismo Passato Past Classicism

Il passato è nel nostro cuore, nella nostra mente, nel nostro futuro; come esseri umani siamo parte di una stupenda famiglia che si tramanda il sapere perché possa esserci d'aiuto come ponte verso il futuro. La geometria è un linguaggio universale arricchito da uomini che hanno fatto della cultura e della scoperta lo scopo della loro vita. In questa parte presentiamo composizioni geometriche di varie provenienze culturali e geografiche che appartengono a differenti periodi storici della scoperta umana. Da secoli sono testimonianza che l'uomo da sempre ama ciò che è universalmente bello.

The past is in our hearts, in our minds, in our future; as human beings we are part of a wonderful family that has been handing down knowledge so that it can be of help as a bridge to the future. Geometry is a universal language, enriched by men who have made culture and discovery the purpose of their life. In this part we show geometric compositions belonging to different historical periods of human discovery. They witness in centuries that man always loves what is universally beautiful.



# Confrontare

## Confrontare

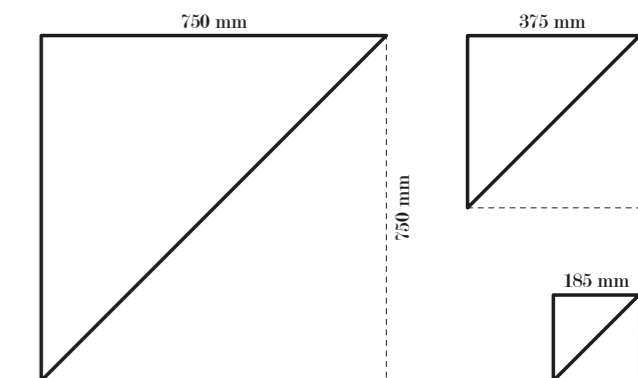

- GEOMETRIA :** CONFRONTARE
- GEOMETRY :** CONFRONTARE
- MATERIALI :** PADOUK & ROVERE ANTRACITE
- MATERIALS :** PADAUK & ANTHRACITE OAK
- PATINA :** NEUTRA / GRIGIO ANTRACITE
- PATINA :** NEUTRAL / ANTHRACITE GREY
- FINITURA :** OLIO
- FINISH :** OIL
- TIPOLOGIA :** BIGLIATO MULTISTRATO
- TYPE :** BOOKMATCHED MULTILAYER PARQUET FLOORING
- SPESORE NOMINALE :** 21 MM
- APPROX. THICKNESS :** 21 MM
- INCASTRO :** MASCHIATURA
- JOINT :** TONGUES AND GROOVES
- BORDATURA :** BISELLATA
- BORDERS :** BEVELED
- LAVORAZIONE SUPERFICIALE :** SPAZZOLATO
- SURFACE TREATMENT :** BRUSHED
- VEISO DELLA VENATURA :** PERSONALIZZABILE
- DIRECTION OF WOOD GRAIN :** CUSTOMIZABLE
- POSA TRAMITE :** COLLANTE
- LAYING WITH :** GLUING DOWN

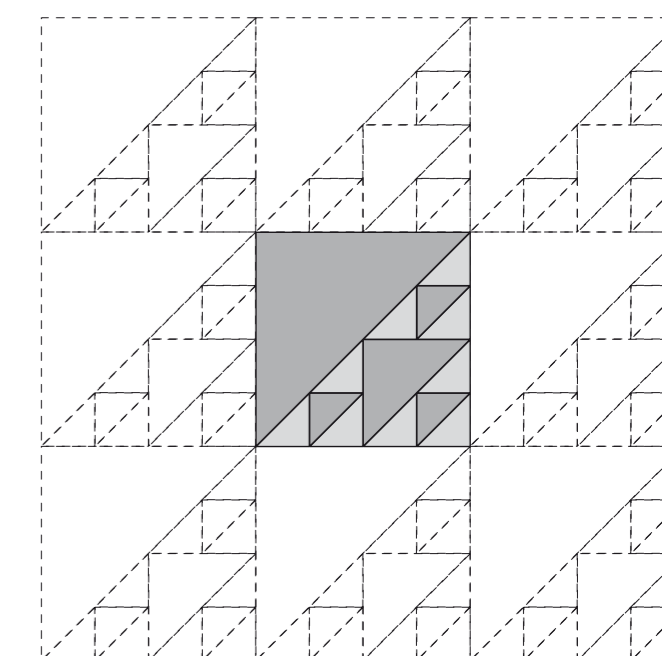

# Interpretare

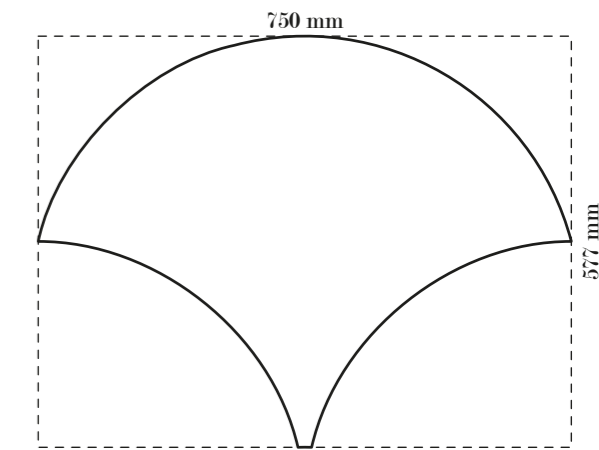

- GEOMETRIA :** INTERPRETARE  
*GEOMETRY :* INTERPRETARE
- MATERIALI :** WENGÉ & ZEBRANO  
*MATERIALS :* WENGE & ZEBRAWOOD
- PATINA :** NEUTRA  
*PATINA :* NEUTRAL
- FINITURA :** OLIO  
*FINISH :* OIL
- TIPOLOGIA :** BIGLIATO MULTISTRATO  
*TYPE :* BOOKMATCHED MULTILAYER PARQUET FLOORING
- SPESORE NOMINALE :** 21 MM  
*APPROX. THICKNESS :* 21 MM
- INCASTRO :** MASCHIATURA  
*JOINT :* TONGUES AND GROOVES
- BORDATURA :** BISELLATA  
*BORDERS :* BEVELED
- LAVORAZIONE SUPERFICIALE :** SPAZZOLATO  
*SURFACE TREATMENT :* BRUSHED
- VERSO DELLA VENATURA :** PERSONALIZZABILE  
*DIRECTION OF WOOD GRAIN :* CUSTOMIZABLE
- POSA TRAMITE :** COLLANTE  
*LAYING WITH :* GLUING DOWN

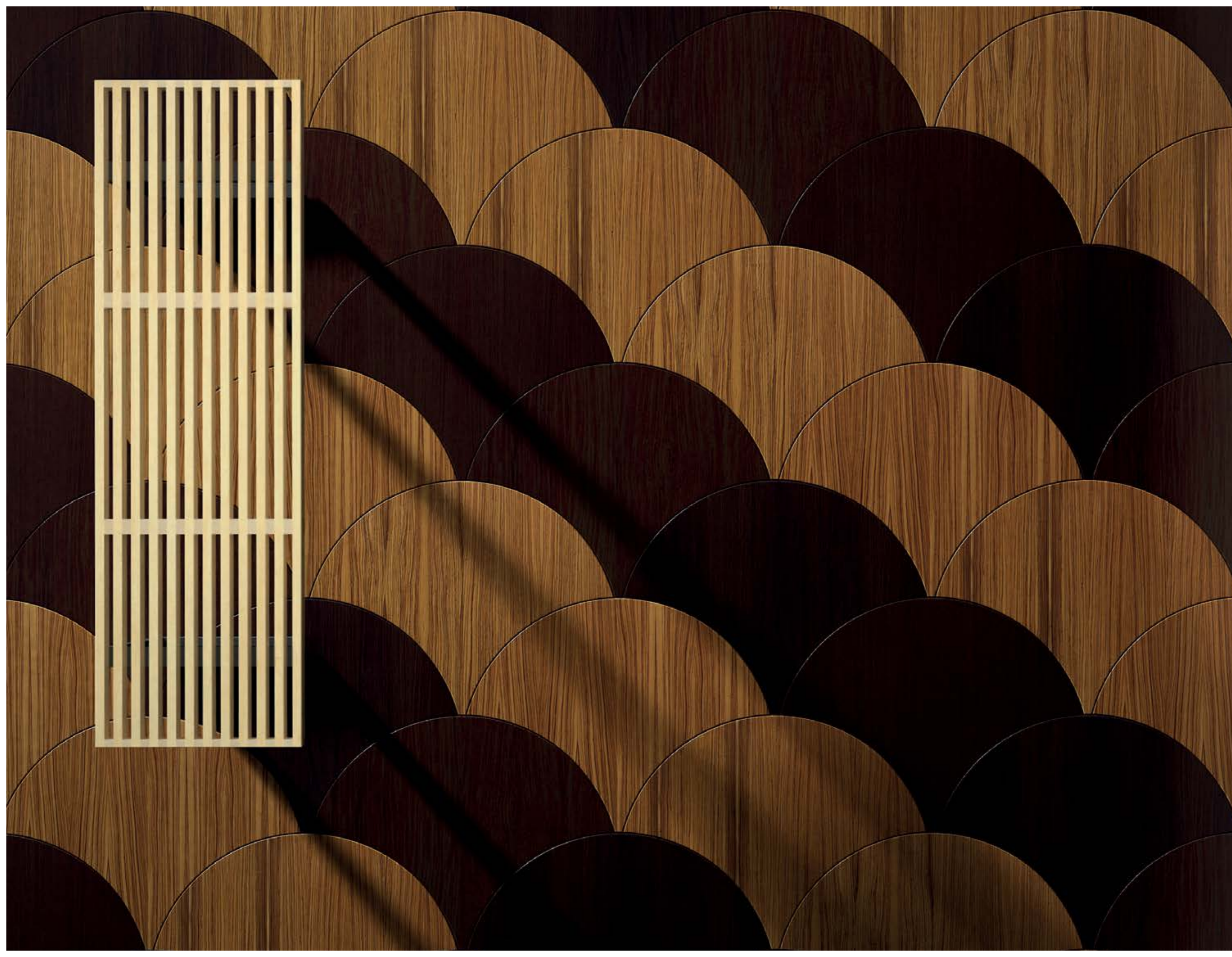
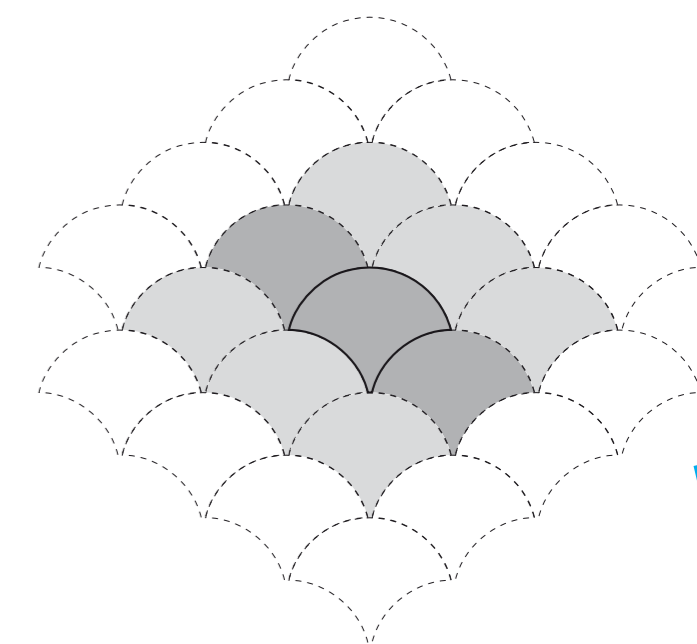

# Invitare

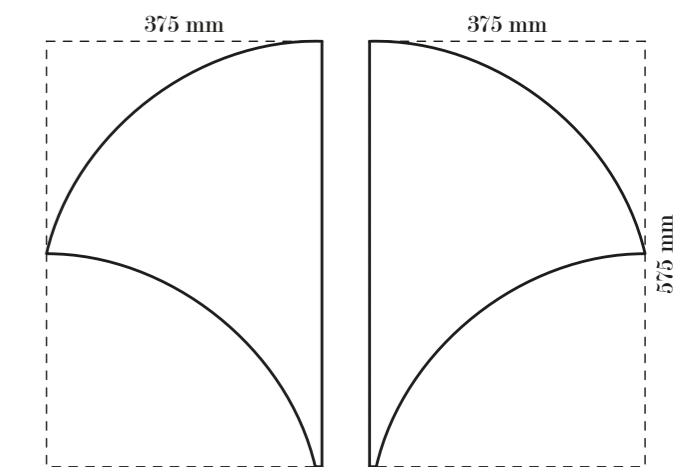
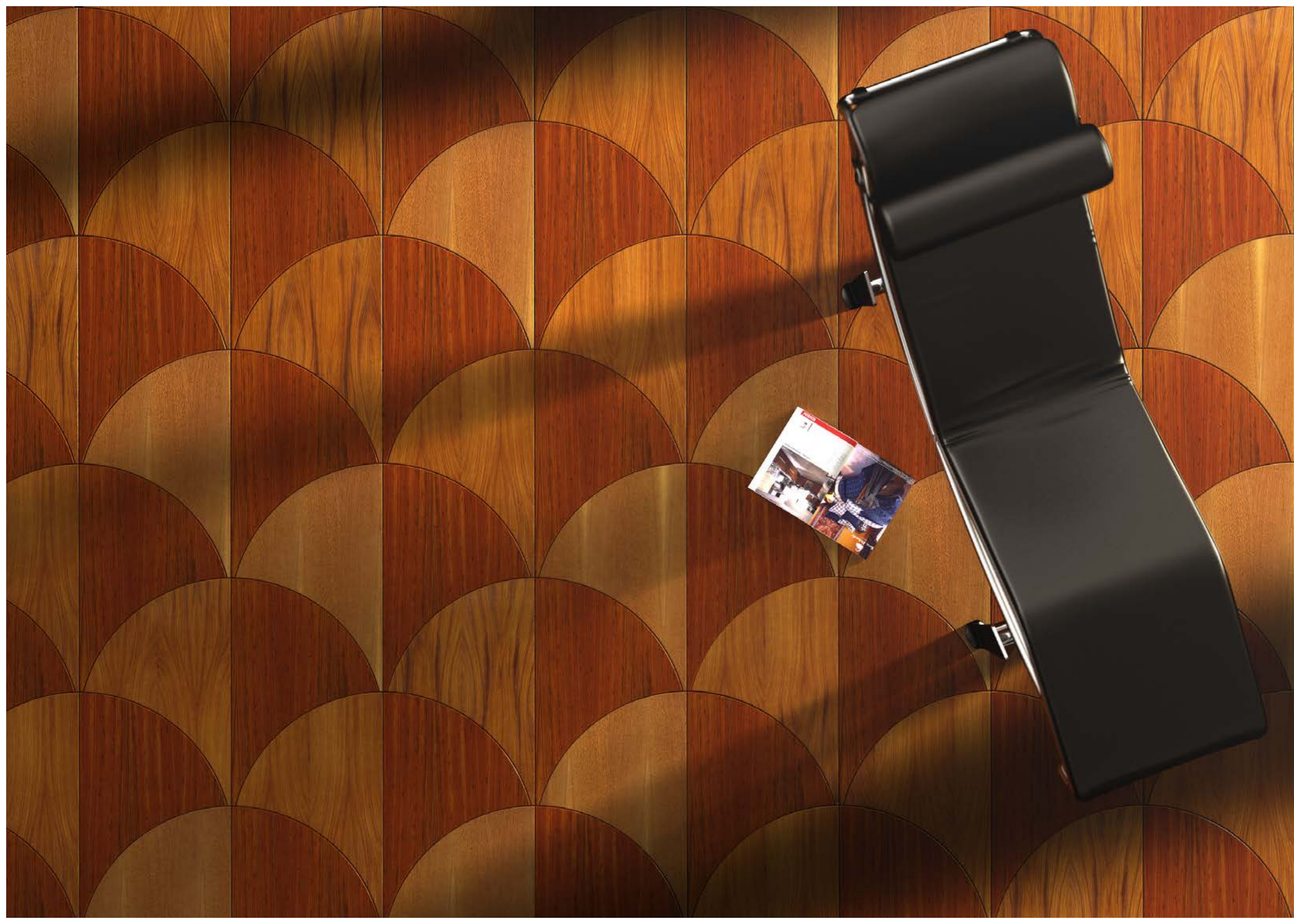

- GEOMETRIA : INVITARE**  
GEOMETRY : INVITARE
- MATERIALI : DOUSSIE & PADOUK**  
MATERIALS : DOUSSIE & PADOUK
- PATINA : NEUTRA**  
PATINA : NEUTRAL
- FINITURA : OLIO**  
FINISH : OIL
- TIPOLOGIA : BIGLIATO MULTISTRATO**  
TYPE : BOOKMATCHED MULTILAYER PARQUET FLOORING
- SPESORE NOMINALE : 21 MM**  
APPROX. THICKNESS : 21 MM
- INCASTRO : MASCHIATURA**  
JOINT : TONGUES AND GROOVES
- BORDATURA : BISELLATA**  
BORDES : BEVELED
- LAVORAZIONE SUPERFICIALE : SPAZOLATO**  
SURFACE TREATMENT : BRUSHED
- VERSO DELLA VENATURA : PERSONALIZZABILE**  
DIRECTION OF WOOD GRAIN : CUSTOMIZABLE
- POSA TRAMITE : COLLANTE**  
LAYING WITH : GLUING DOWN

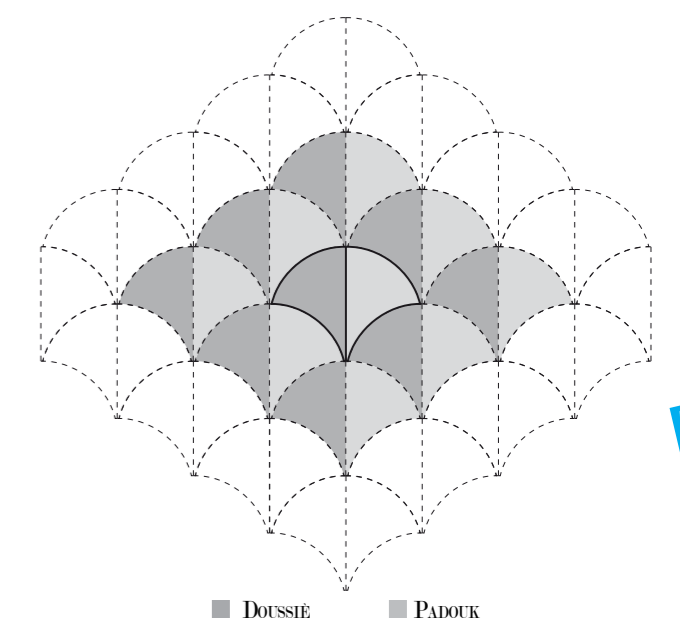

# Esultare

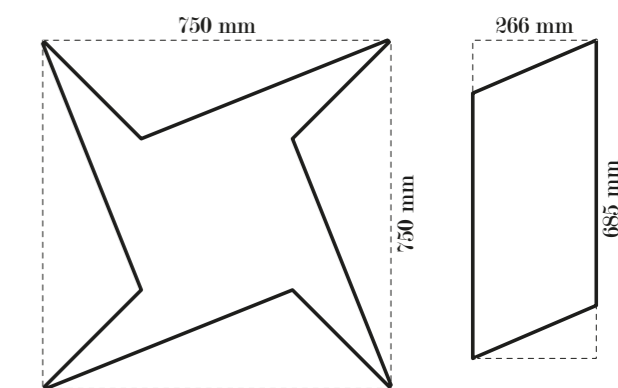

**GEOMETRIA : ESULTARE**  
**GEOMETRY : ESULTARE**

**MATERIALI : ZEBRANO & WENGÉ**  
**MATERIALS : ZEBRAWOOD & WENGE**

**PATINA : NEUTRA / GRIGIO ANTRACITE**  
**PATINA : NEUTRAL / ANTHRACITE GREY**

**FINITURA : OLIO**  
**FINISH : OIL**

**TIPOLOGIA : BIGLIATO MULTISTRATO**  
**TYPE : BOOKMATCHED MULTILAYER PARQUET FLOORING**

**SPESORE NOMINALE : 21 MM**  
**APPROX. THICKNESS : 21 MM**

**INCASTRO : MASCHIATURA**  
**JOINT : TONGUES AND GROOVES**

**BORDATURA : BISELLATA**  
**BORDERS : BEVELED**

**LAVORAZIONE SUPERFICIALE : SPAZZOLATO**  
**SURFACE TREATMENT : BRUSHED**

**VERSO DELLA VENATURA : PERSONALIZZABILE**  
**DIRECTION OF WOOD GRAIN : CUSTOMIZABLE**

**POSA TRAMITE : COLLANTE**  
**LAYING WITH : GLUING DOWN**

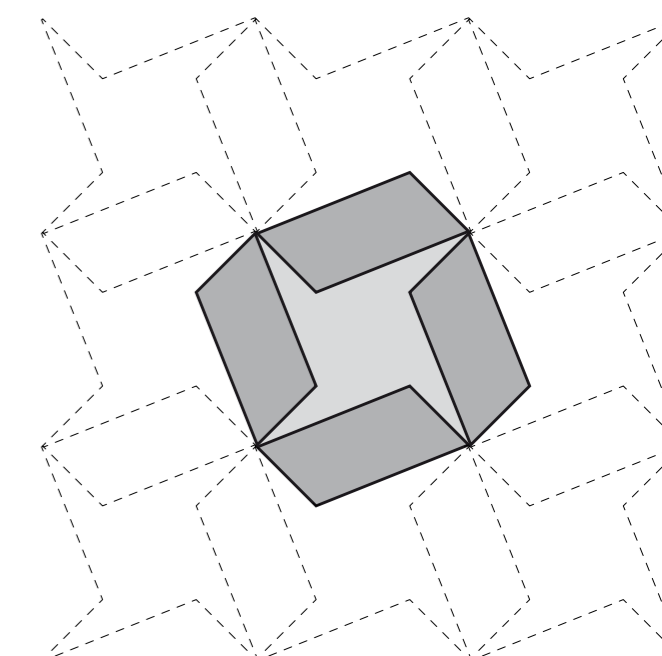



# Esplorare

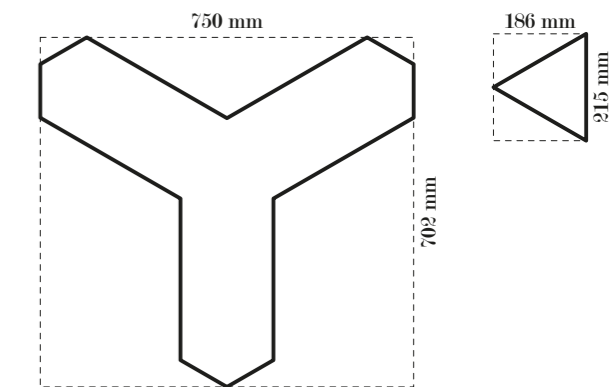

**GEOMETRIA : ESPLORARE**  
 GEOMETRY : ESPLORARE

**MATERIALI : PADOUK, ZEBRANO, WENGÉ & NOCE EUROPEO**  
 MATERIALS : PADOUK, ZEBRAWOOD, WENGÉ & EUROPEAN WALNUT

**PATINA : NEUTRA**  
 PATINA : NEUTRAL

**FINITURA : OLIO**  
 FINISH : OIL

**TIPOLOGIA : BIGLIATO MULTISTRATO**  
 TYPE : BOOKMATCHED MULTILAYER PARQUET FLOORING

**SPESORE NOMINALE : 21 MM**  
 APPROX. THICKNESS : 21 MM

**INCASTRO : MASCHIATURA**  
 JOINT : TONGUES AND GROOVES

**BORDATURA : BISELLATA**  
 BORDERS : BEVELED

**LAVORAZIONE SUPERFICIALE : SPAZZOLATO**  
 SURFACE TREATMENT : BRUSHED

**VERSO DELLA VENATURA : PERSONALIZZABILE**  
 DIRECTION OF WOOD GRAIN : CUSTOMIZABLE

**POSA TRAMITE : COLLANTE**  
 LAYING WITH : GLUING DOWN

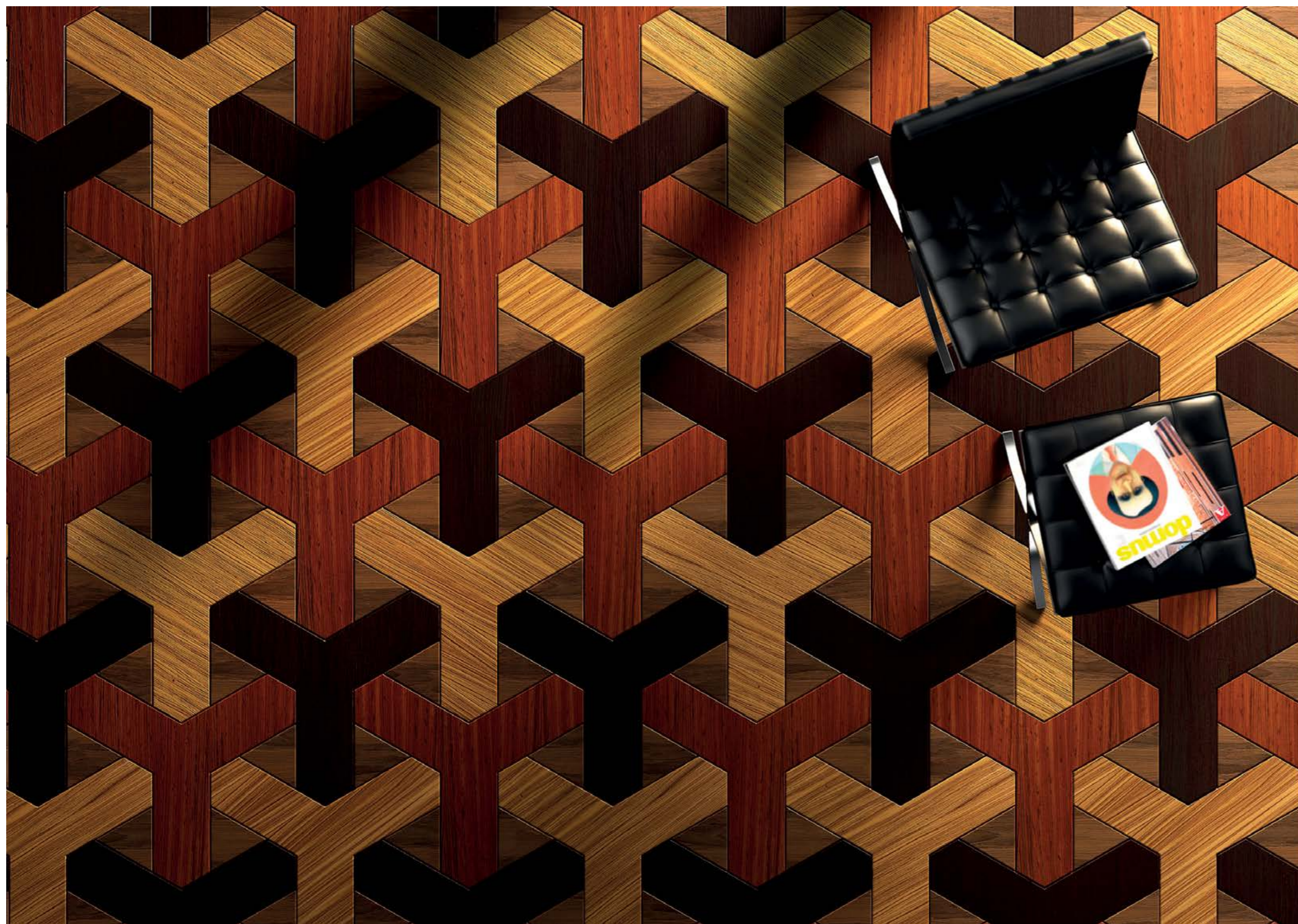
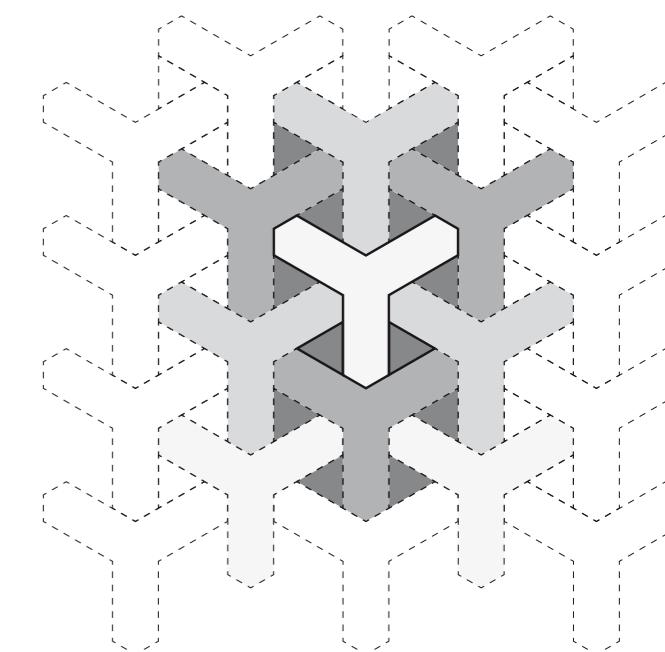

# Immaginare

## Immaginare

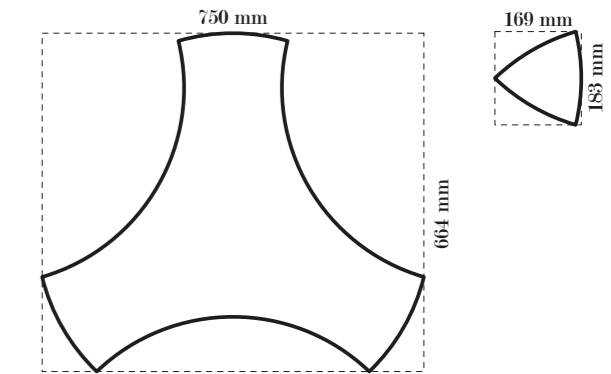

**GEOMETRIA : IMMAGINARE**  
*GEOMETRY : IMMAGINARE*

**MATERIALI : PADOCK, ZEBRANO, WENGÉ & NOCE EUROPEO**  
*MATERIALS : PADOCK, ZEBRAWOOD, WENGÉ & EUROPEAN WALNUT*

**PATINA : NEUTRA**  
*PATINA : NEUTRAL*

**FINITURA : OLIO**  
*FINISH : OIL*

**TIPOLOGIA : BIGLIATO MULTISTRATO**  
*TYPE : BOOKMATCHED MULTILAYER PARQUET FLOORING*

**SPESORE NOMINALE : 21 MM**  
*APPROX. THICKNESS : 21 MM*

**INCASTRO : MASCHIATURA**  
*JOINT : TONGUES AND GROOVES*

**BORDATURA : BISELLATA**  
*BORDERS : BEVELED*

**LAVORAZIONE SUPERFICIALE : SPAZZOLATO**  
*SURFACE TREATMENT : BRUSHED*

**VERSO DELLA VENATURA : PERSONALIZZABILE**  
*DIRECTION OF WOOD GRAIN : CUSTOMIZABLE*

**POSA TRAMITE : COLLANTE**  
*LAYING WITH : GLUING DOWN*

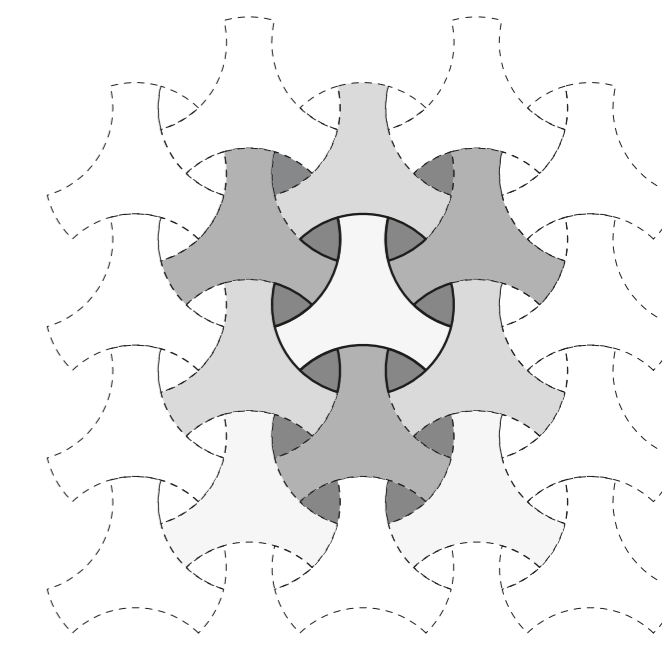

# Incastrare

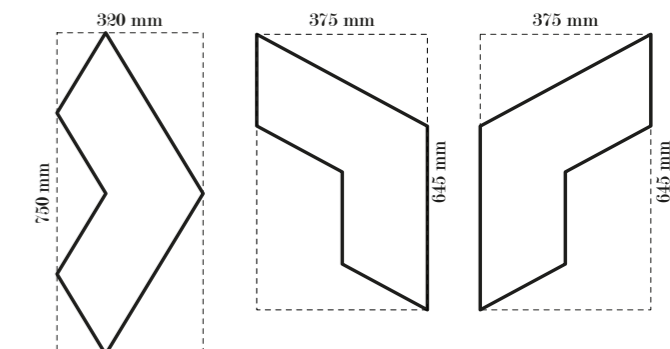

**GEOMETRIA : INCASTRARE**  
**GEOMETRY : INCASTRARE**

**MATERIALI : EBANO, PALISSANDRO INDIA & RADICA**  
**MATERIALS : EBONY, INDIAN ROSEWOOD & BRIAR ROOT**

**PATINA : NEUTRA**  
**PATINA : NEUTRAL**

**FINITURA : OLIO**  
**FINISH : OIL**

**TIPOLOGIA : BIGLIATO MULTISTRATO**  
**TYPE : BOOKMATCHED MULTILAYER PARQUET FLOORING**

**SPESORE NOMINALE : 21 MM**  
**APPROX. THICKNESS : 21 MM**

**INCASTRO : MASCHIATURA**  
**JOINT : TONGUES AND GROOVES**

**BORDATURA : BISELLATA**  
**BORDERS : BEVELED**

**LAVORAZIONE SUPERFICIALE : SPAZZOLATO**  
**SURFACE TREATMENT : BRUSHED**

**VERSO DELLA VENATURA : PERSONALIZZABILE**  
**DIRECTION OF WOOD GRAIN : CUSTOMIZABLE**

**POSA TRAMITE : COLLANTE**  
**LAYING WITH : GLUING DOWN**

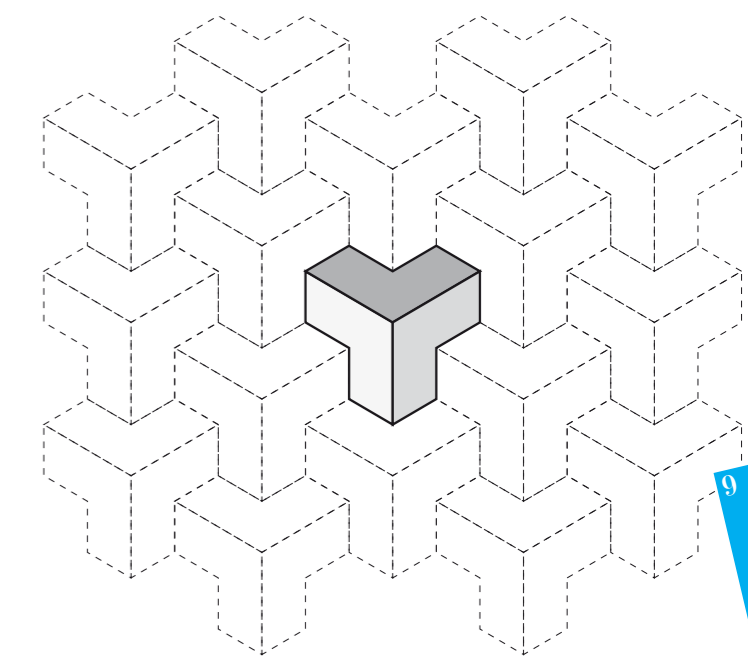

# Tetrissando Playing Tetris

Giocare con la geometria, con i pezzi che si combinano tra loro riempiendo spazi vuoti, arricchendo superfici con la loro presenza.  
Come calamite si attraggono consapevoli di avere una collocazione ben precisa, di far parte di qualche cosa, di contribuire ad un risultato finale che non potrà essere ripetuto.  
Ogni ambiente è unico, come lo è ogni pezzo in quella precisa posizione, in quella dimensione e formato comunicando sensazioni che emergono dal colore del legno, dalla sua unica venatura e sfumatura.  
Geometrie spigolose, ma duttili e pulite; tessere dai molteplici lati ortogonali e paralleli in un contrasto di dinamismo e staticità.  
Difficile definirlo; potenziale elemento di un minimalismo elaborato oppure un semplice gioco rivisitato.

Play with geometry, with pieces that fit together filling gaps, enriching surfaces with their presence.  
As magnets they attract each other, aware of having a precise location, of being part of something, of contributing to a final result that can not be repeated.  
Each setting is unique, as every piece in that exact position is, in that size and format communicating feelings that emerge from the color of the wood, from its unique grain and nuance.  
Angular geometries, thus supple and clean; tiles with multiple orthogonal and parallel sides in a contrast of dynamism and statics.  
Difficult to define; potential element of an ornate minimalism or a simple game revisited.



# Collegare

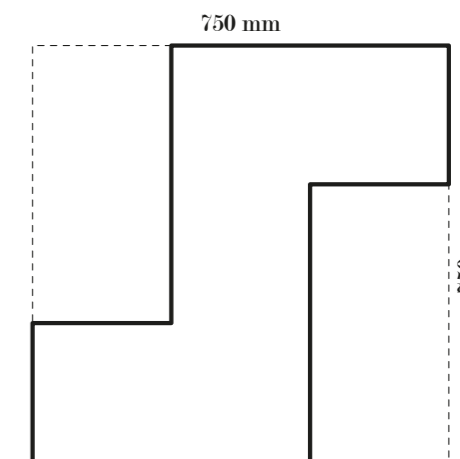

**GEOMETRIA : COLLEGARE**  
*GEOMETRY : COLLEGARE*

**MATERIALI : ROVERE**  
*MATERIALS : OAK*

**PATINA : BIANCA, PERLA, SILVER & ANTRACITE**  
*PATINA : WHITE, PEARL, SILVER & ANTHRACITE*

**FINITURA : OLIO**  
*FINISH : OIL*

**TIPOLOGIA : BIGLIATO MULTISTRATO**  
*TYPE : BOOKMATCHED MULTILAYER PARQUET FLOORING*

**SPESSORE NOMINALE : 21 MM**  
*APPROX. THICKNESS : 21 MM*

**INCASTRO : MASCHIATURA**  
*JOINT : TONGUES AND GROOVES*

**BORDATURA : BISELLATA**  
*BORDES : BEVELED*

**LAVORAZIONE SUPERFICIALE : SPAZZOLATO**  
*SURFACE TREATMENT : BRUSHED*

**VERSO DELLA VENATURA : PERSONALIZZABILE**  
*DIRECTION OF WOOD GRAIN : CUSTOMIZABLE*

**POSA TRAMITE : COLLANTE**  
*LAYING WITH : GLUING DOWN*

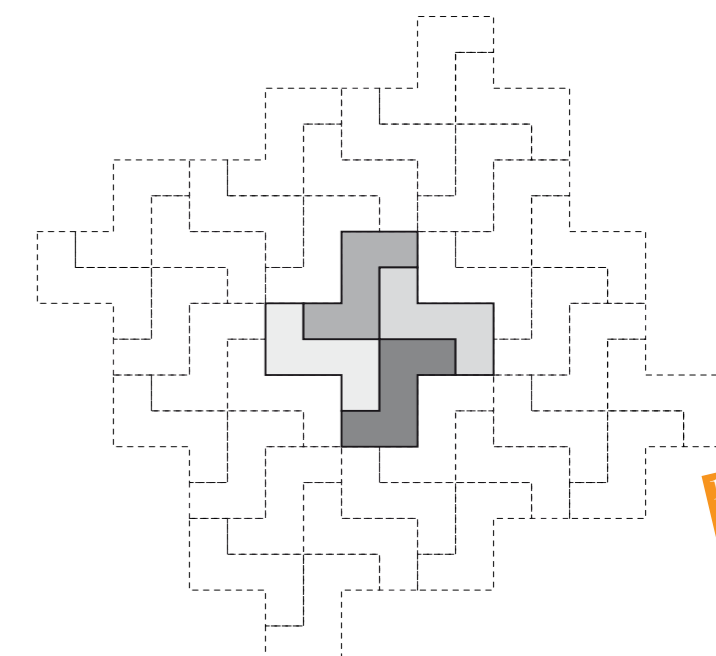

# Raggruppare

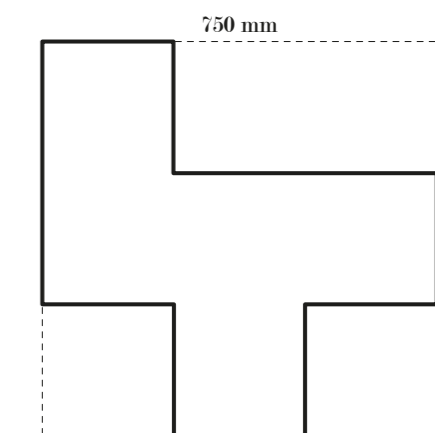

**GEOMETRIA : RAGGRUPPARE**  
 GEOMETRY : RAGGRUPPARE

**MATERIALI : ROVERE**  
 MATERIALS : OAK

**PATINA : NEUTRA, MOKA, RAMATA & SBIANCATA**  
 PATINA : NEUTRAL, MOKA, AUBURN & BLEACH

**FINITURA : OLIO**  
 FINISH : OIL

**TIPOLOGIA : BIGLIATO MULTISTRATO**  
 TYPE : BOOKMATCHED MULTILAYER PARQUET FLOORING

**SPESSORE NOMINALE : 21 MM**  
 APPROX. THICKNESS : 21 MM

**INCASTRO : MASCHIATURA**  
 JOINT : TONGUES AND GROOVES

**BORDATURA : BISCELLATA**  
 BORDERS : BEVELED

**LAVORAZIONE SUPERFICIALE : SPAZZOLATO**  
 SURFACE TREATMENT : BRUSHED

**VERSO DELLA VENATURA : PERSONALIZZABILE**  
 DIRECTION OF WOOD GRAIN : CUSTOMIZABLE

**POSA TRAMITE : COLLANTE**  
 LAYING WITH : GLUING DOWN

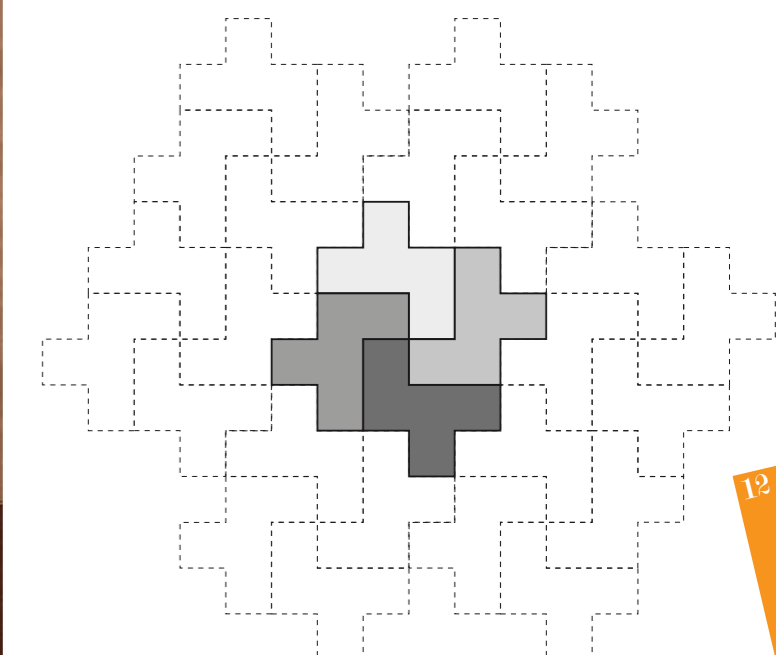

# Tassellature Artistiche Artistic Tassellations

Incastri dolci, delicati, incredibilmente sottili per astuzia e precisione che si sviluppano in una trama spettacolare di dimensioni, forme e colori. Pezzi unici, moduli che coprono superfici importanti, forme geometriche indecifrabili se prese singolarmente, ma fondamentali parti di un progetto che segue la logica ed il desiderio del suo creatore per arrivare dove lui vuole che si arrivi.  
Un linguaggio tutto da scrivere.

Smooth and delicate framing, incredibly subtle and accurate, that develops in a spectacular plot of sizes, shapes and colors. Unique pieces, modules that cover important surfaces, geometric shapes indecipherable when taken individually, but fundamental parts of a project that follows the logic and the desire of its creator to get where he wants to.  
A language to be written.

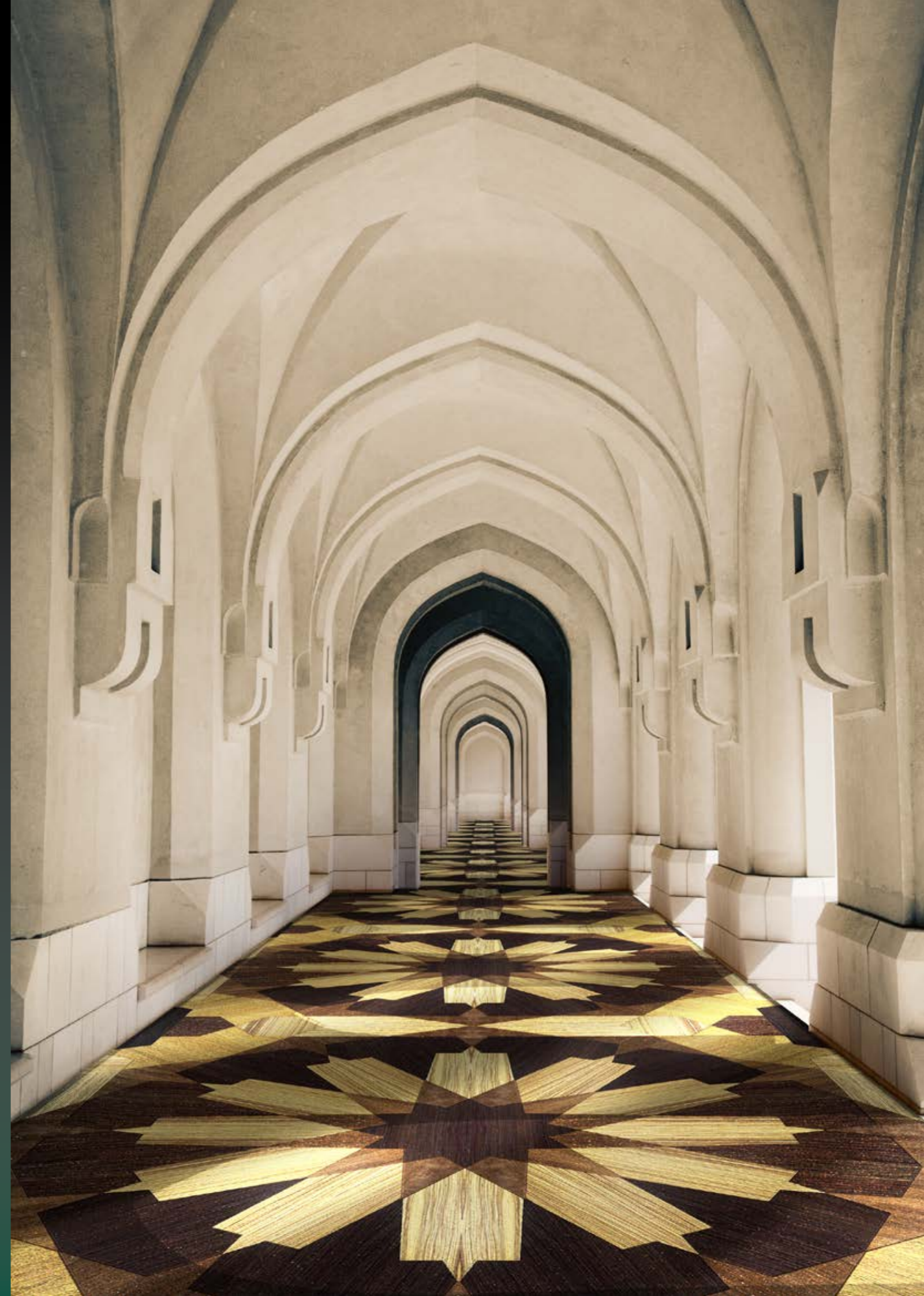

# Accogliere

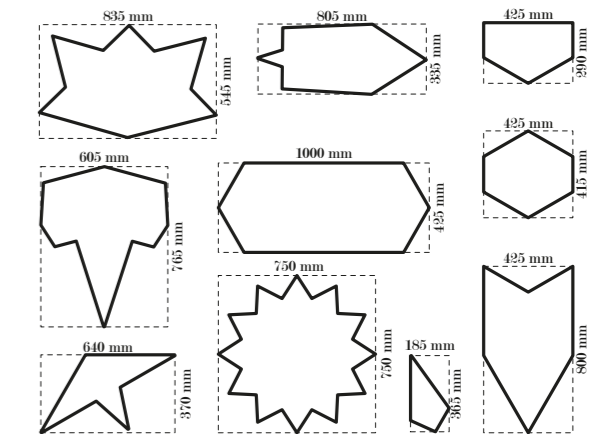

**GEOMETRIA : ACCOGLIERE**  
**GEOMETRY : ACCOGLIERE**

**MATERIALI : WENGE, TEAK BURMA, ZEBRANO & ROVERE**  
**MATERIALS : WENGE, BURMA TEAK, ZEBRAWOOD & OAK**

**PATINA : NEUTRA**  
**PATINA : NEUTRAL**

**FINITURA : OLIO**  
**FINISH : OIL**

**TIPOLOGIA : BIGLIATO MULTISTRATO**  
**TYPE : BOOKMATCHED MULTILAYER PARQUET FLOORING**

**SPESORE NOMINALE : 21 MM**  
**APPROX. THICKNESS : 21 MM**

**INCASTRO : MASCHIATURA**  
**JOINT : TONGUES AND GROOVES**

**BORDATURA : BISELLATA**  
**BORDERS : BEVELED**

**LAVORAZIONE SUPERFICIALE : SPAZZOLATO**  
**SURFACE TREATMENT : BRUSHED**

**VERSO DELLA VENATURA : PERSONALIZZABILE**  
**DIRECTION OF WOOD GRAIN : CUSTOMIZABLE**

**POSA TRAMITE : COLLANTE**  
**LAYING WITH : GLUING DOWN**

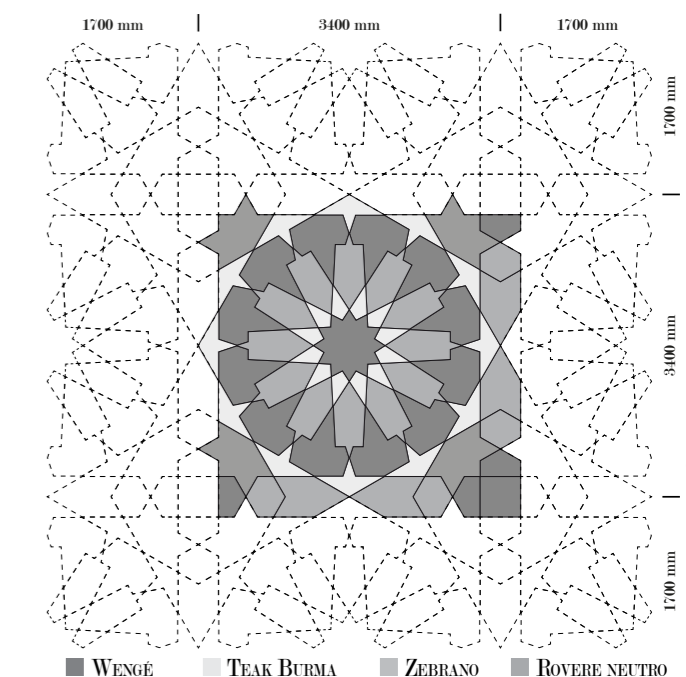



# Avvolgere

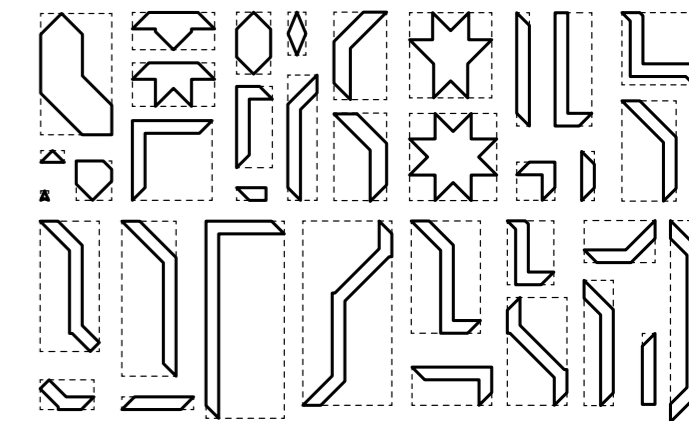

- GEOMETRIA : AVVOLGERE**  
GEOMETRY : AVVOLGERE
- MATERIALI : PADOCK, ZEBRANO, ROVERE NEUTRO & WENGÉ**  
MATERIALS : PADOCK, ZEBRAWOOD, NEUTRAL OAK & WENGÉ
- PATINA : NEUTRA**  
PATINA : NEUTRAL
- FINITURA : OLIO**  
FINISH : OIL
- TIPOLOGIA : BIGLIATO MULTISTRATO**  
TYPE : BOOKMATCHED MULTILAYER PARQUET FLOORING
- SPESORE NOMINALE : 21 MM**  
APPROX. THICKNESS : 21 MM
- INCASTRO : MASCHIATURA**  
JOINT : TONGUES AND GROOVES
- BORDATURA : BISELLATA**  
BORDERS : BEVELED
- LAVORAZIONE SUPERFICIALE : SPAZZOLATO**  
SURFACE TREATMENT : BRUSHED
- VERSO DELLA VENATURA : PERSONALIZZABILE**  
DIRECTION OF WOOD GRAIN : CUSTOMIZABLE
- POSA TRAMITE : COLLANTE**  
LAYING WITH : GLUING DOWN

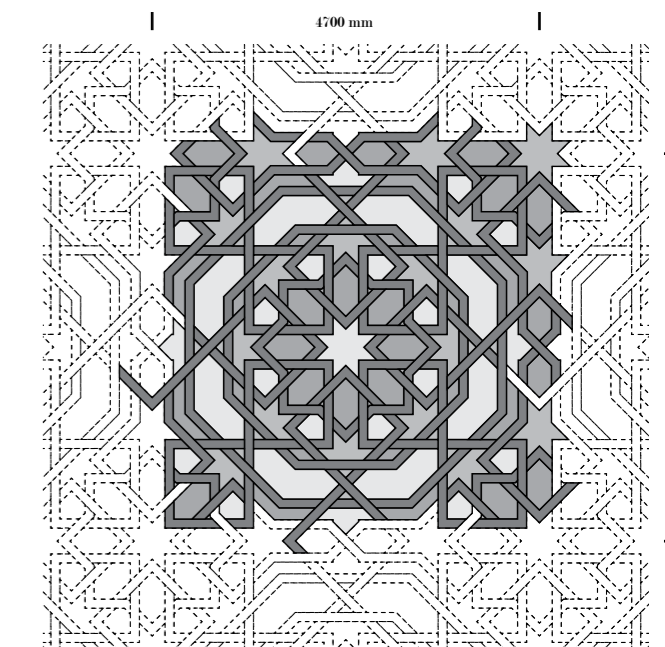

# Conoscere

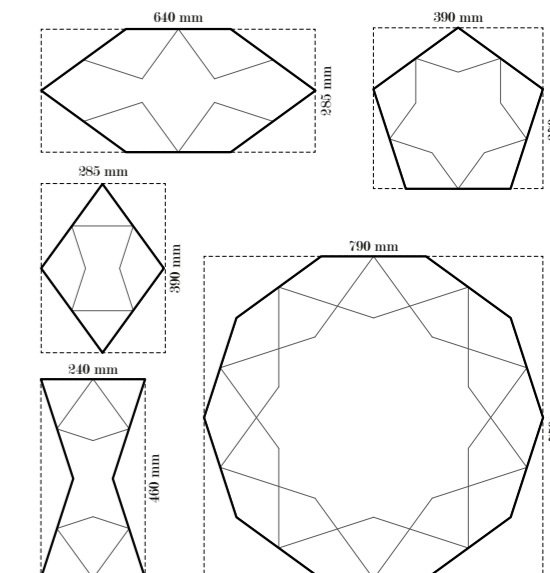

**GEOMETRIA : CONOSCERE**  
**GEOMETRY : CONOSCERE**

**MATERIALI : PADOUK & TEAK**  
**MATERIALS : PADOUK & TEAK**

**PATINA : NEUTRA**  
**PATINA : NEUTRAL**

**FINITURA : OLIO**  
**FINISH : OIL**

**TIPOLOGIA : BIGLIATO MULTISTRATO PANTOGRAFATO**  
**TYPE : BOOKMATCHED MULTILAYER PARQUET PANTOGRAPHED**

**SPESORE NOMINALE : 21 MM**  
**APPROX. THICKNESS : 21 MM**

**INCASTRO : MASCHIATURA**  
**JOINT : TONGUES AND GROOVES**

**BORDATURA : BISELLATA**  
**BORDERS : BEVELED**

**LAVORAZIONE SUPERFICIALE : SPAZZOLATO**  
**SURFACE TREATMENT : BRUSHED**

**VERSO DELLA VENATURA : PERSONALIZZABILE**  
**DIRECTION OF WOOD GRAIN : CUSTOMIZABLE**

**POSA TRAMITE : COLLANTE**  
**LAYING WITH : GLUING DOWN**

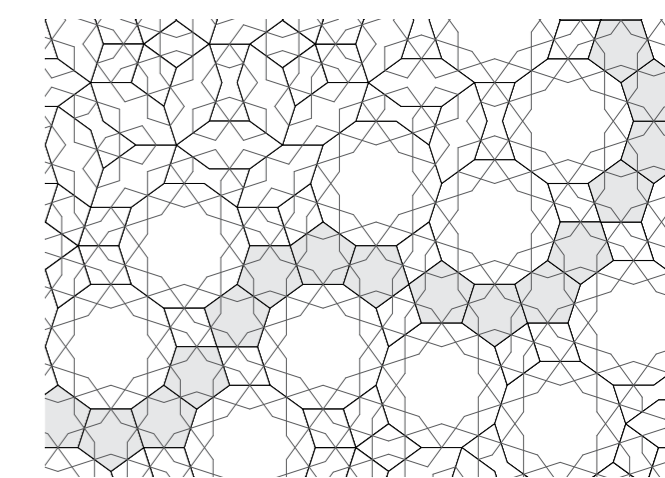

# Algoritmicamente Algorithmically

Un rompicapo per i più, per coloro che fin da piccoli, da sempre odiano la matematica come se fosse un mostro, un orco inutile che ha il solo scopo di perseguitarci fin dai primi anni di scuola.

In realtà è un mondo affascinante ed illimitatamente fecondo di novità e scoperte, di angoli segreti e meravigliosi tutti da scoprire.

Una sorgente di acqua pura che attraverso calcoli matematici ci permette di realizzare composizioni, geometrie senza apparente inizio né fine, senza modularità e senza limiti.

Gli algoritmi; uno strumento potentissimo, ma c'è molto di più.

A puzzle for most people, for those who since childhood have always hated Math as if it were a monster, an ogre who has the only target of haunting them from the early school years.

It's actually a fascinating and unlimitedly fruitful world of news and discoveries, of secret and wonderful corners to discover.

A source of pure water that, through mathematical calculations, allow us to create compositions, geometries with no apparent beginning or end, without modularity and limitless.

Algorithms are a powerful tool, but there is much more.



# Ideare

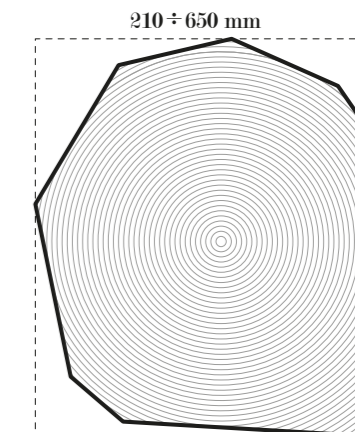

**GEOMETRIA : IDEARE**  
GEOMETRY : IDEARE

**MATERIALI : WENGÉ**  
MATERIALS : WENGÉ

**PATINA : NEUTRA**  
PATINA : NEUTRAL

**FINITURA : OLIO**  
FINISH : OIL

**TIPOLOGIA : BIGLIATO MULTISTRATO**  
TYPE : BOOKMATCHED MULTILAYER PARQUET FLOORING

**SPESORE NOMINALE : 21 MM**  
APPROX. THICKNESS : 21 MM

**INCASTRO : MASCHIATURA**  
JOINT : TONGUES AND GROOVES

**BORDATURA : BISELLATA**  
BORDERS : BEVELED

**LAVORAZIONE SUPERFICIALE : SPAZZOLATO**  
SURFACE TREATMENT : BRUSHED

**VERSO DELLA VENATURA : PERSONALIZZABILE**  
DIRECTION OF WOOD GRAIN : CUSTOMIZABLE

**POSA TRAMITE : COLLANTE**  
LAYING WITH : GLUING DOWN

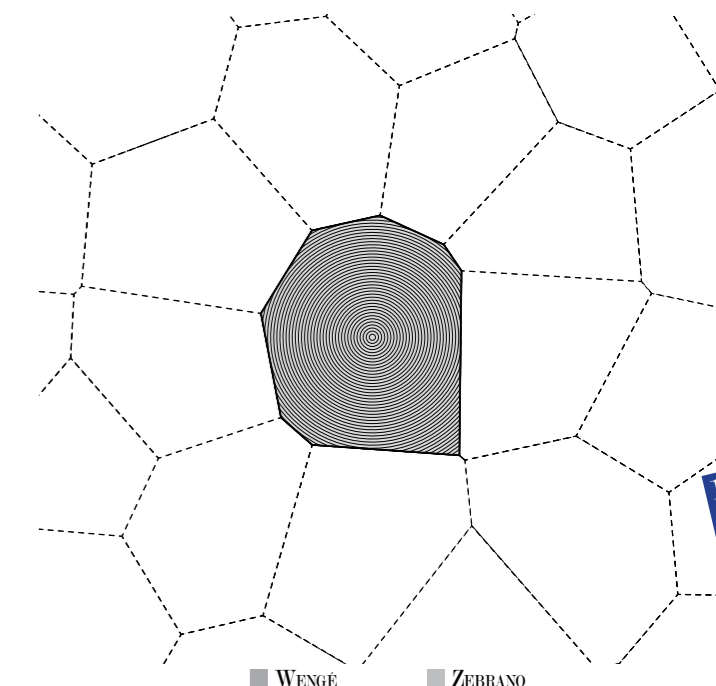

# Attrarre

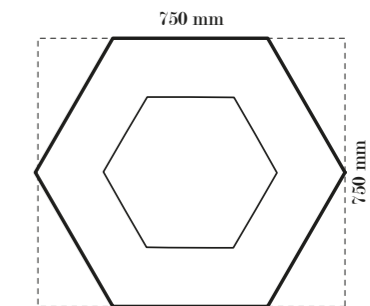

- GEOMETRIA : ATTRARRE**  
GEOMETRY : ATTRARRE
- MATERIALI : DOUSSE & PADOUR**  
MATERIALS : DOUSSE & PADOUR
- PATINA : NEUTRA**  
PATINA : NEUTRAL
- FINITURA : OLIO**  
FINISH : OIL
- TIPOLOGIA : PANNELLO**  
TYPE : ASSEMBLED PANNEL
- SPESORE NOMINALE : 21 MM**  
APPROX. THICKNESS : 21 MM
- INCASTRO : MASCHIATURA**  
JOINT : TONGUES AND GROOVES
- BORDATURA : BISELLATA**  
BORDEIS : BEVELED
- LAVORAZIONE SUPERFICIALE : SPAZZOLATO**  
SURFACE TREATMENT : BRUSHED
- VERSO DELLA VENATURA : PERSONALIZZABILE**  
DIRECTION OF WOOD GRAIN : CUSTOMIZABLE
- POSA TRAMITE : COLLANTE**  
LAYING WITH : GLUING DOWN

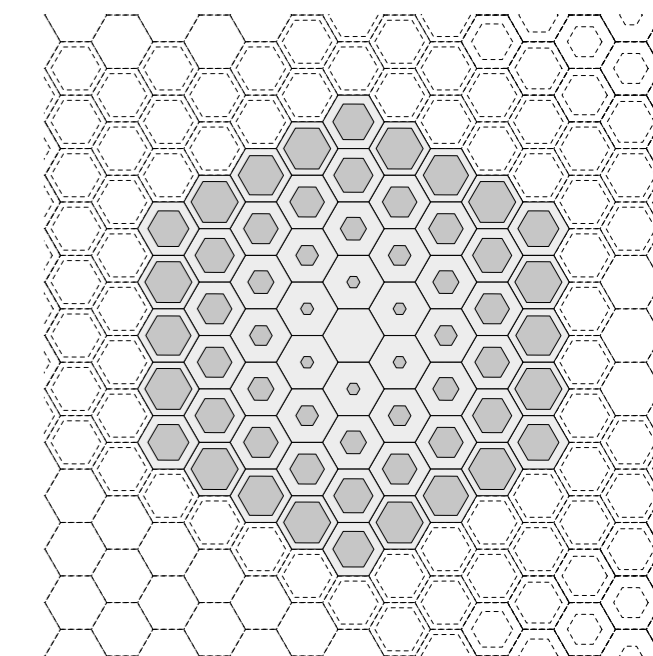

# Attirare

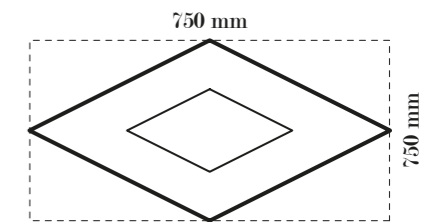

- GEOMETRIA : ATTIRARE**  
GEOMETRY : ATTIRARE
- MATERIALI : ZEBRANO & TEAK**  
MATERIALS : ZEBRAWOOD & TEAK
- PATINA : NEUTRA**  
PATINA : NEUTRAL
- FINITURA : OLIO**  
FINISH : OIL
- TIPOLOGIA : PANNELLO ASSEMBLATO**  
TYPE : ASSEMBLED PANNEL
- SPESSORE NOMINALE : 21 MM**  
APPROX. THICKNESS : 21 MM
- INCASTRO : MASCHIATURA**  
JOINT : TONGUES AND GROOVES
- BORDATURA : BISELLATA**  
BORDES : BEVELED
- LAVORAZIONE SUPERFICIALE : SPAZZOLATO**  
SURFACE TREATMENT : BRUSHED
- VEISO DELLA VENATURA : PERSONALIZZABILE**  
DIRECTION OF WOOD GRAIN : CUSTOMIZABLE
- POSA TRAMITE : COLLANTE**  
LAYING WITH : GLUING DOWN

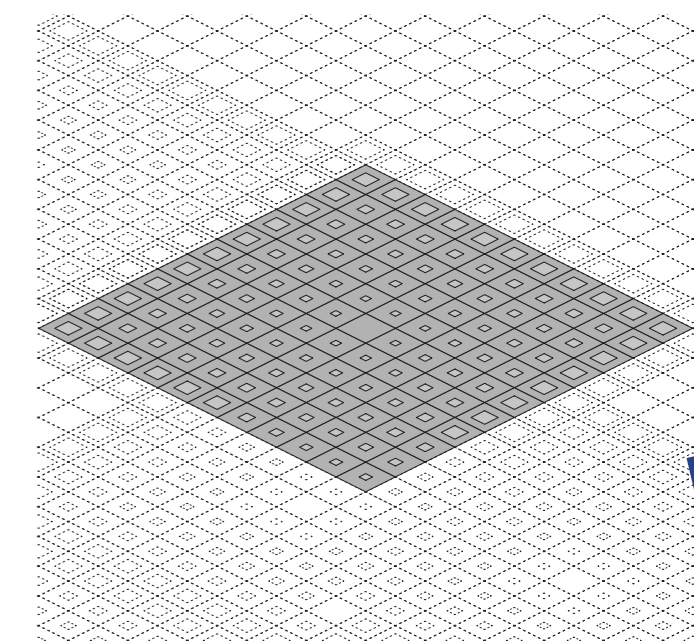

# Geometrie Lignee Wooden Geometries

La geometria comunicata attraverso le sue forme e combinazioni; alcuni esempi di ciò che può essere realizzato. Uno spunto perché possiate creare in libertà. Infiniti giochi compositivi, lavorazioni superficiali senza limiti e patine personalizzabili portano matematicamente ad un numero stupefacente di risultati. La versione in rovere massello riflette in ogni pezzo la sua matericità; la versione multistrato offre nella sua gamma numerosissima di specie legnose delle dimensioni eccezionali arricchite dalla composizione a libro di ogni pezzo. Un paradiso per tutti i creativi senza freni.

Geometry expressed in its forms and combinations; some examples of what can be created. Some ideas that could allow you to create without limits. Unlimited solutions for a composition, wide range of surface works and customized patinas lead to incredible number of results. A version in solid oak wood reflects its materiality in each element; a multilayer version offers in its wide range of wood species exceptional dimensions enriched with book matching of each element. This is a real paradise for all creative people with no brakes.



# Regina

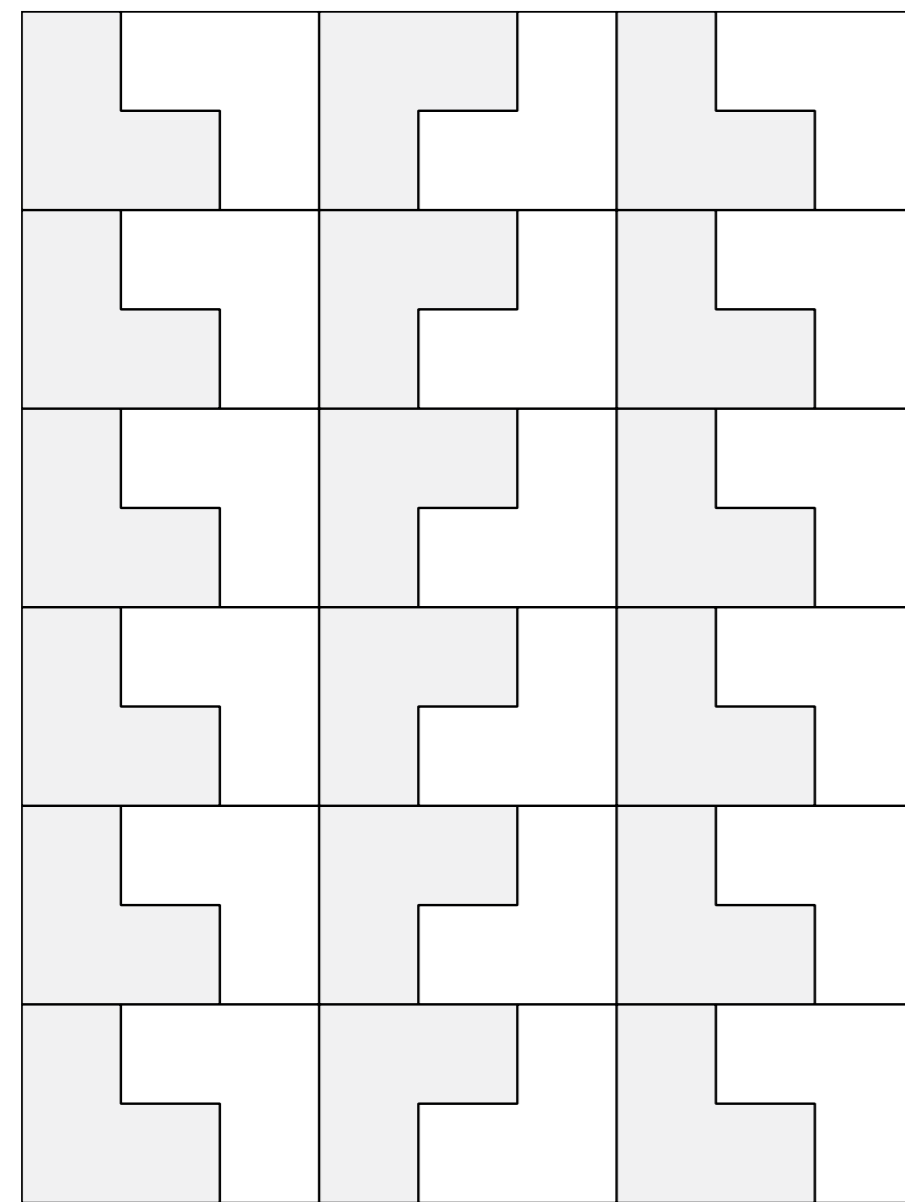

# Sole

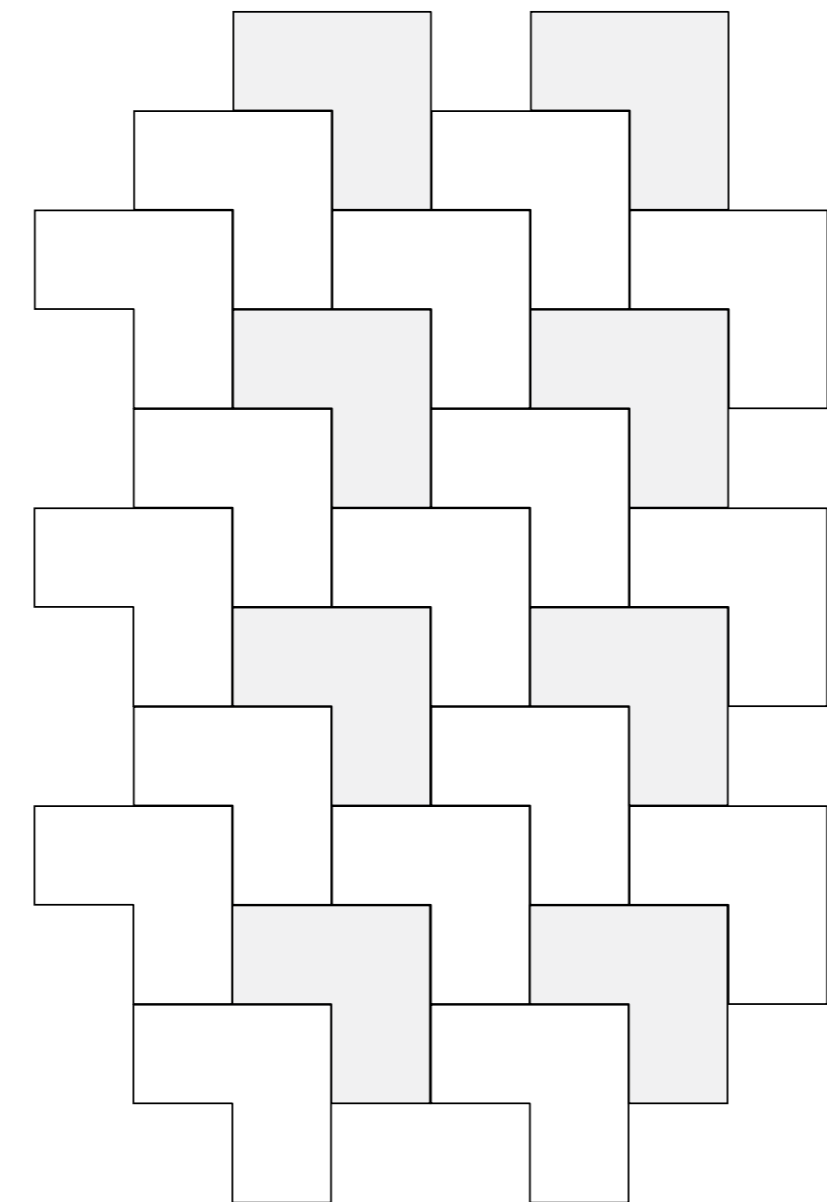

# Lucina

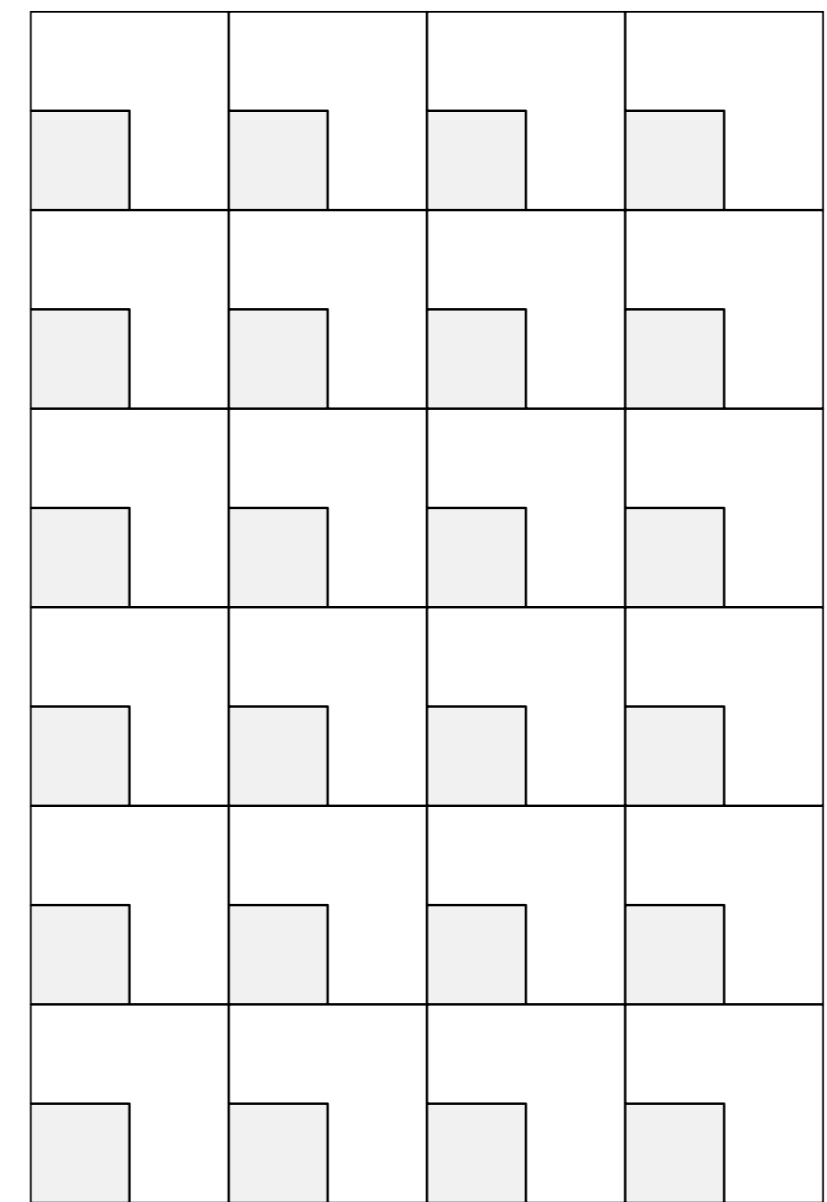

SOLID WOOD / MULTILAYER

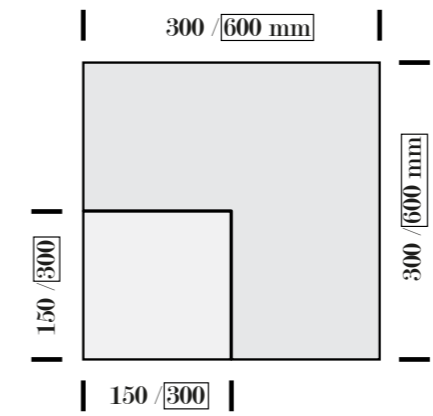
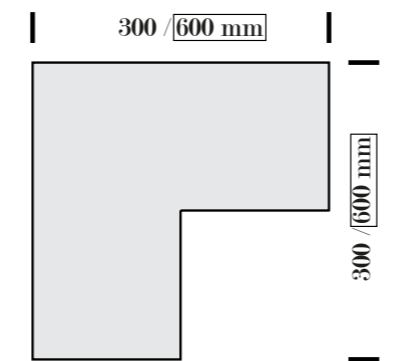
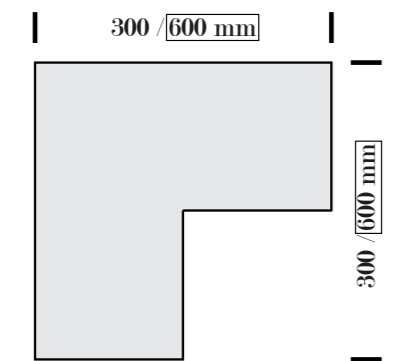



# Giove

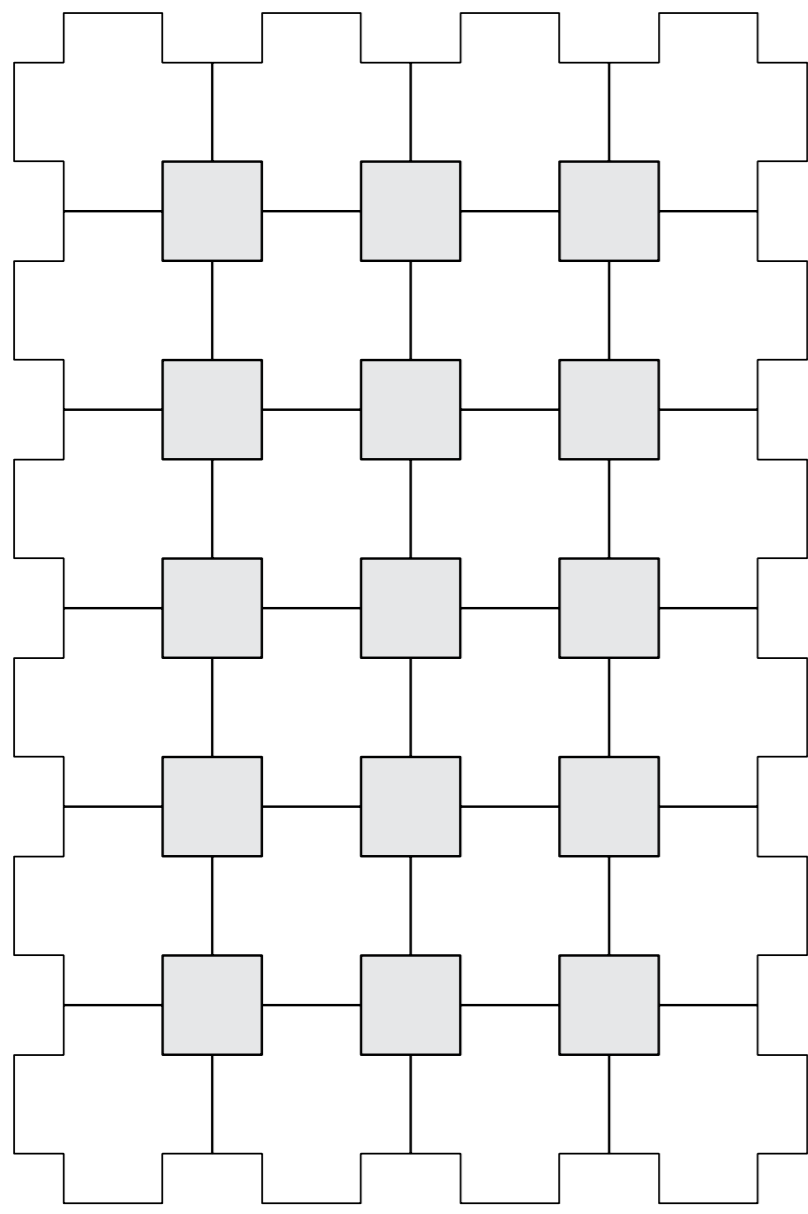

SOLID WOOD / MULTILAYER

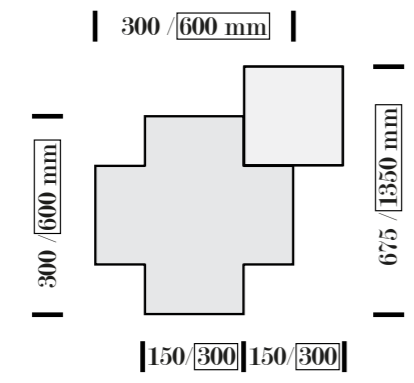

# Minerva

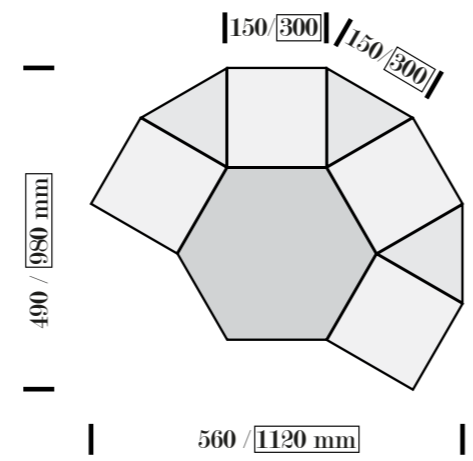
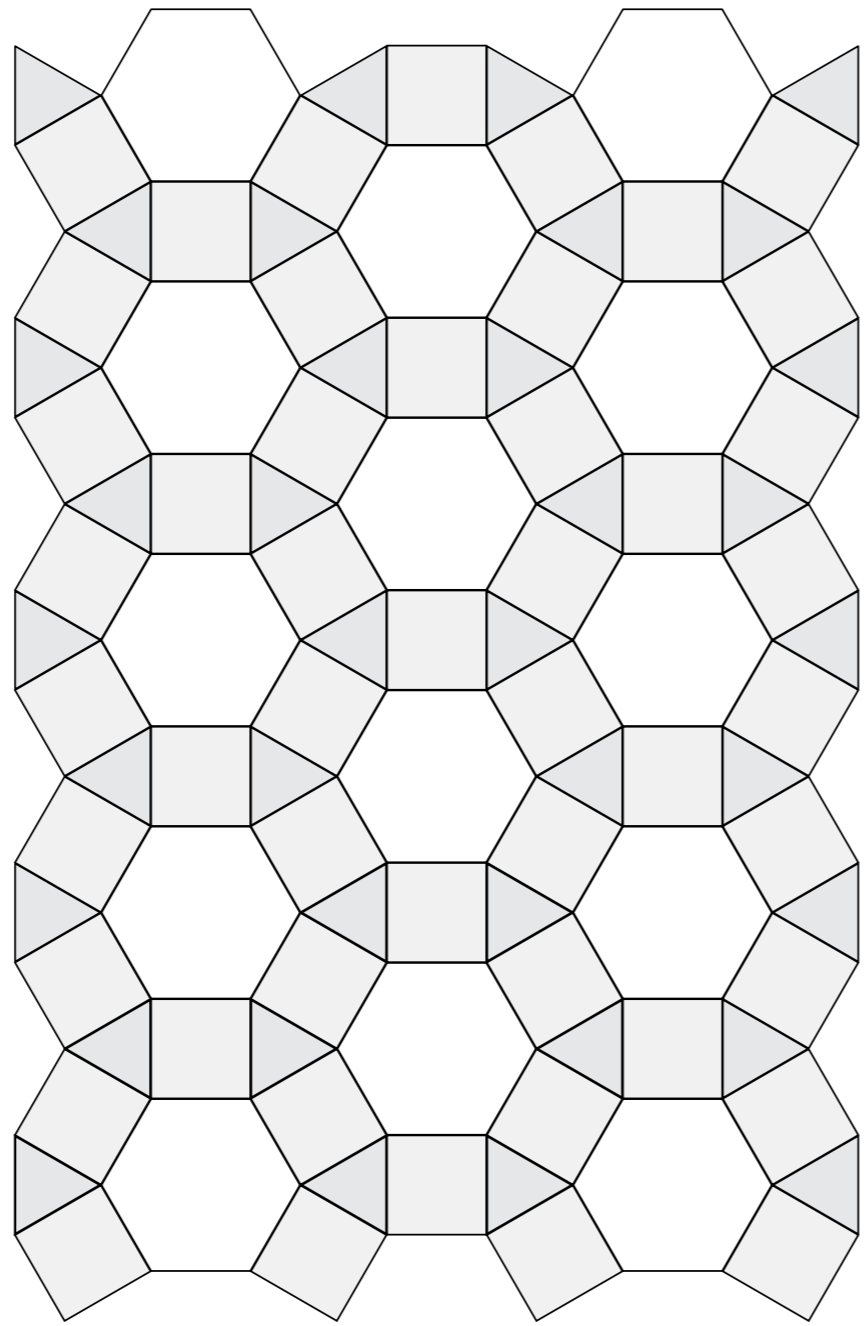

# Marte

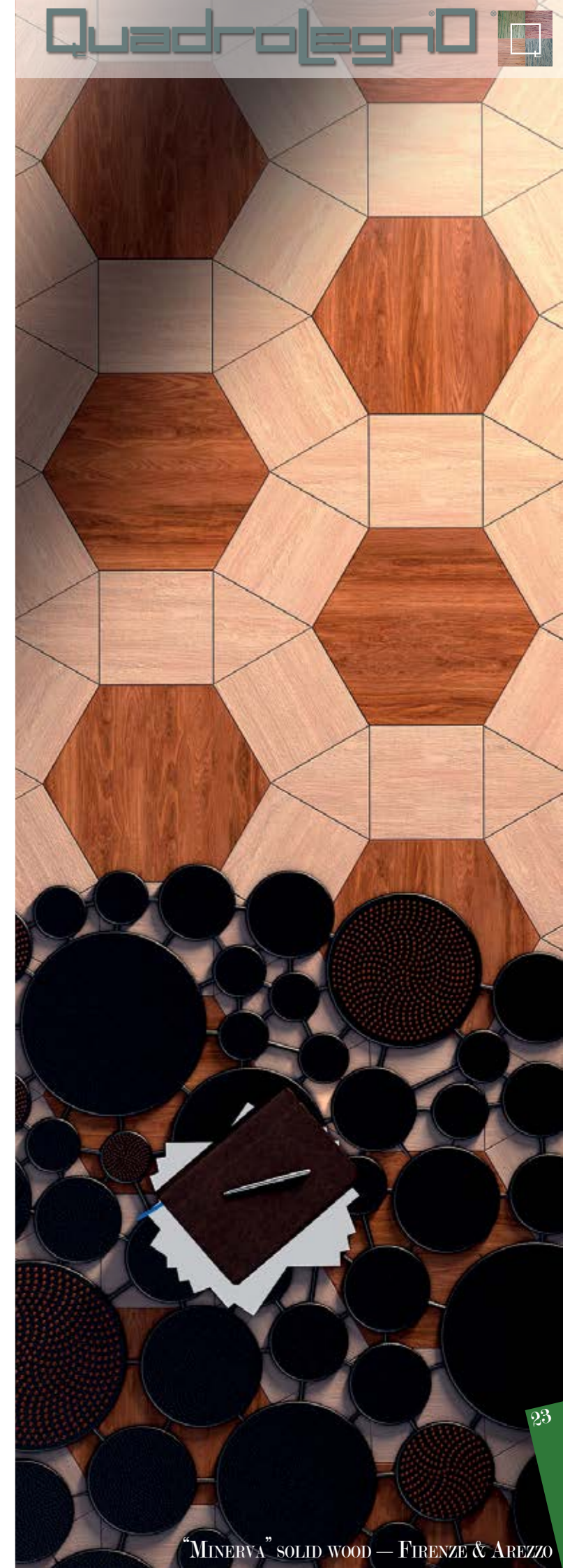
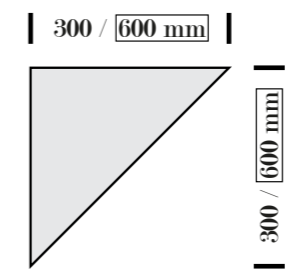
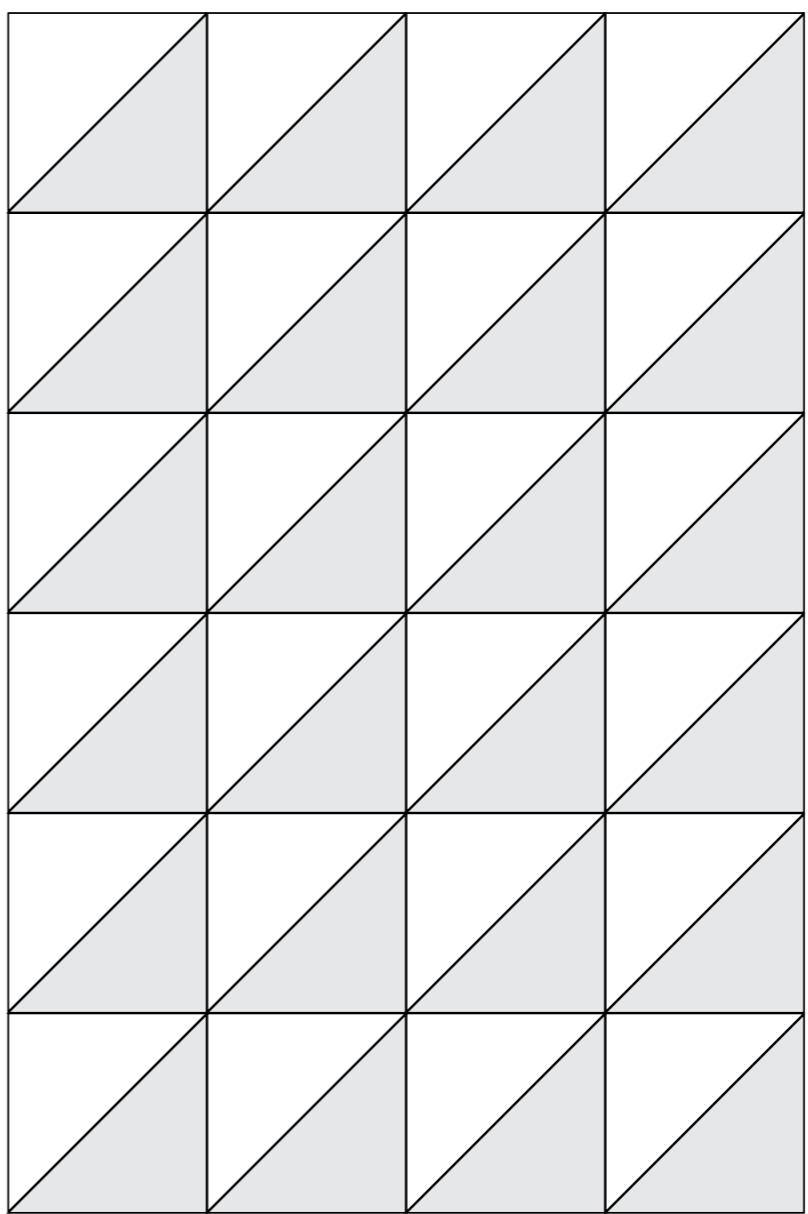

# Venere

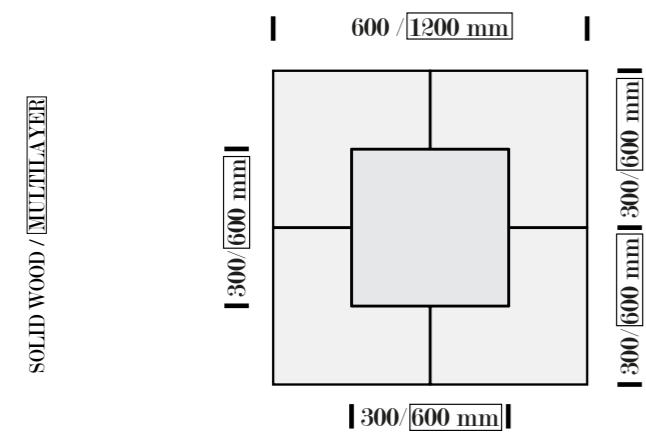
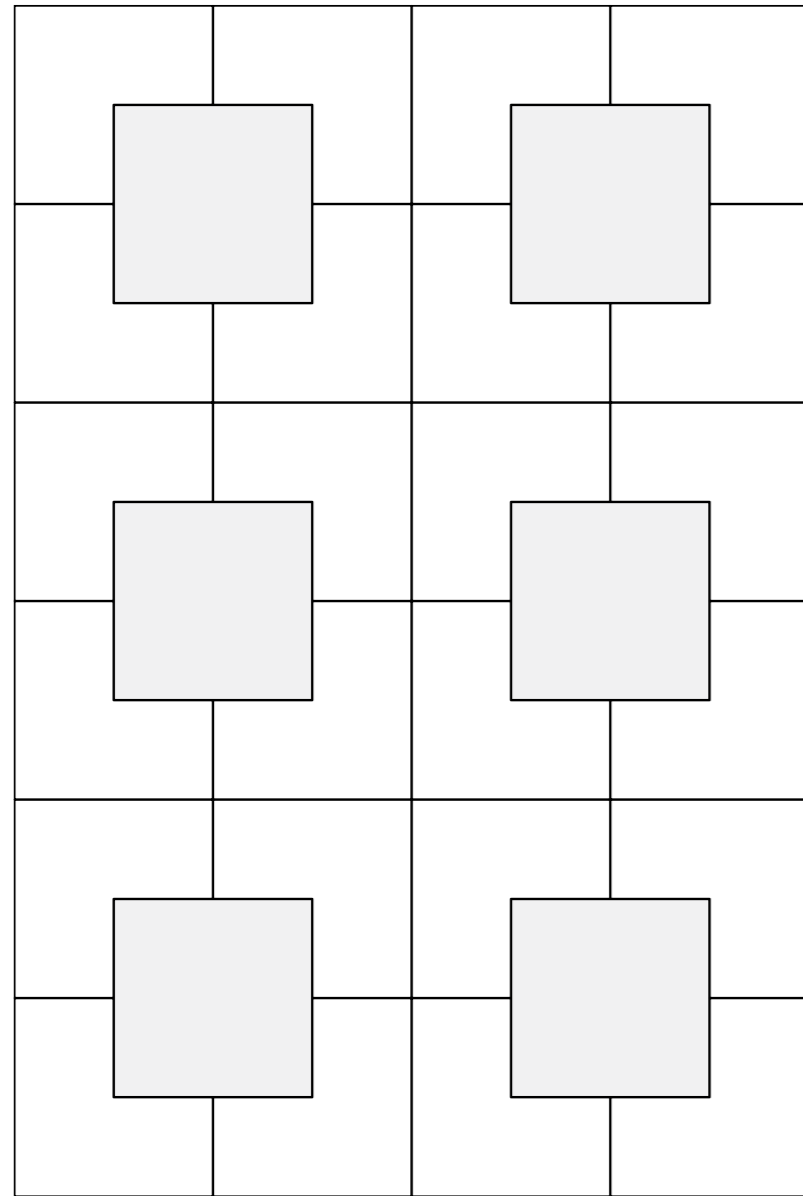

# Cupido

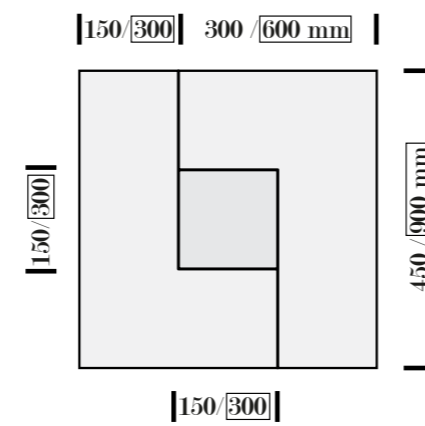
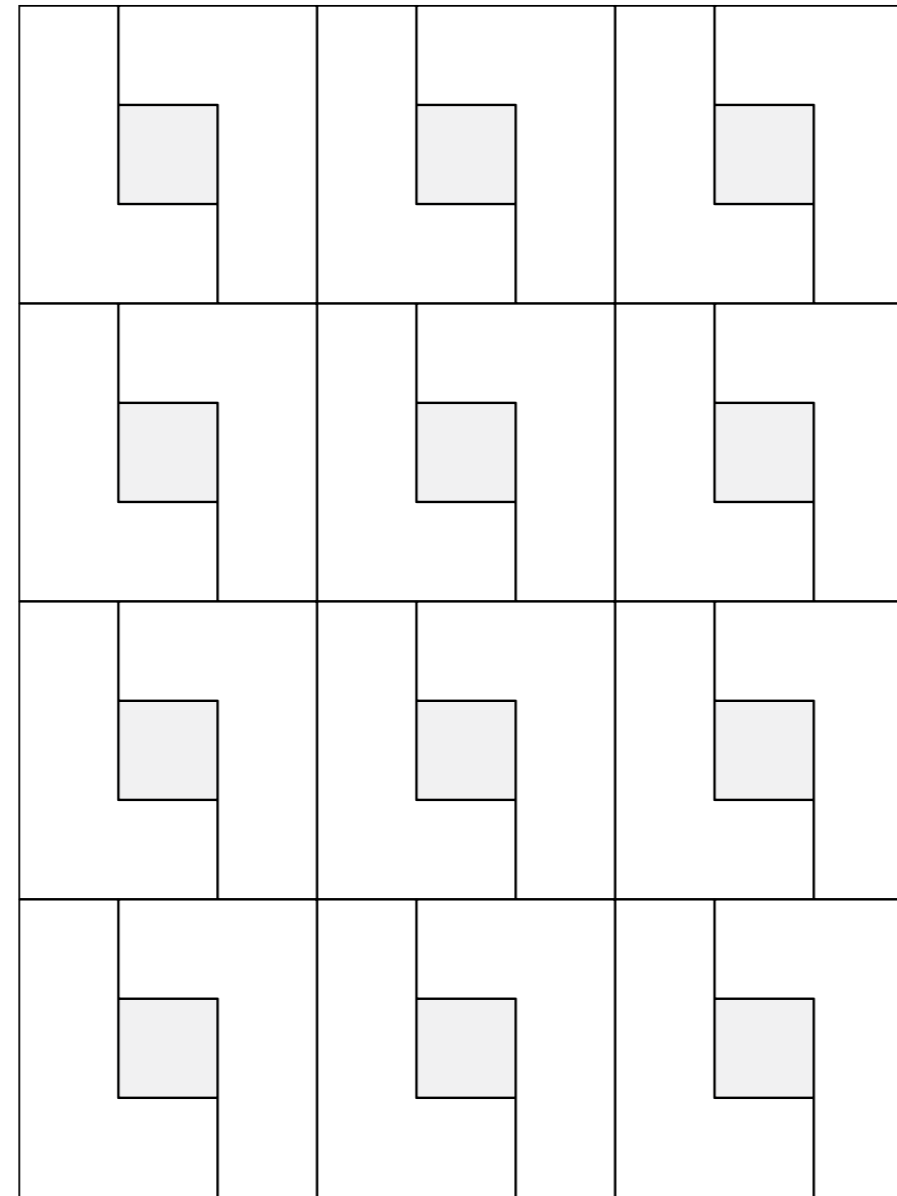

# Giunone

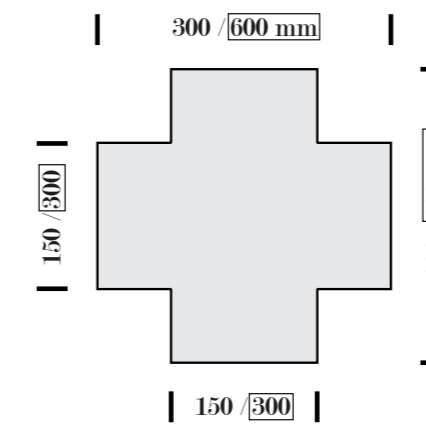
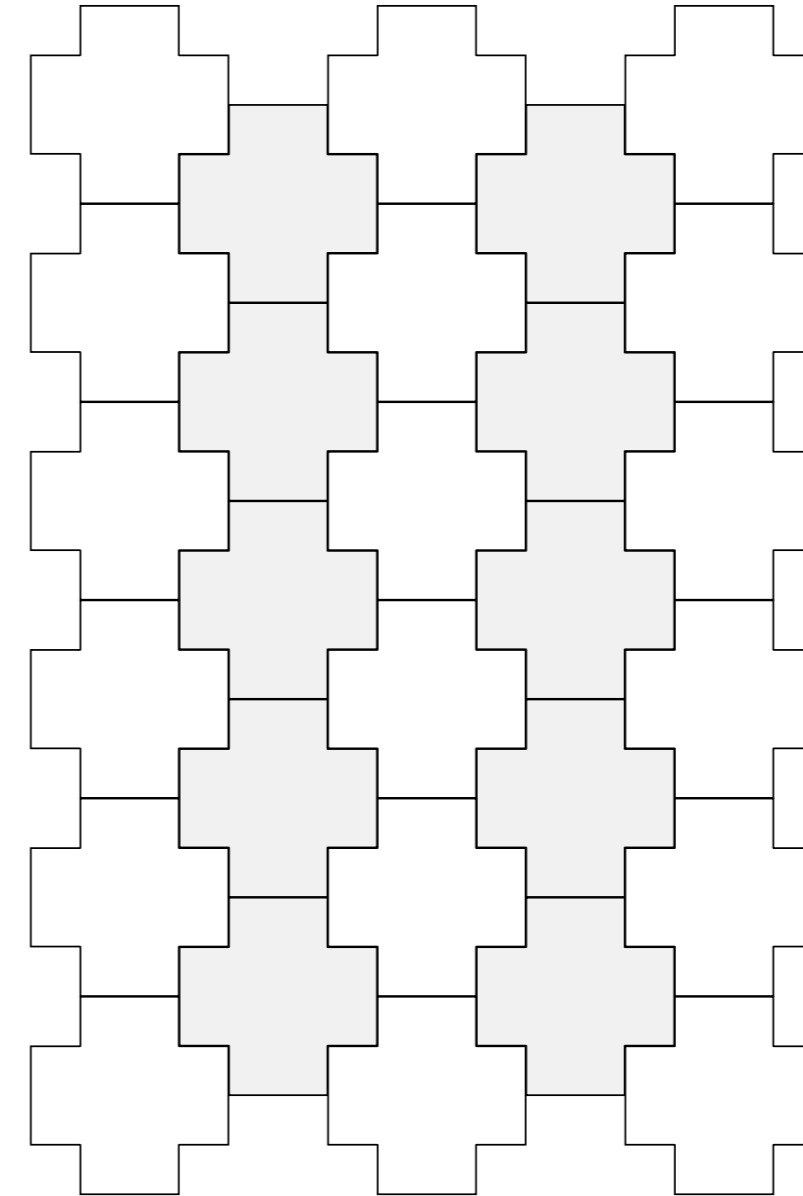

# Mercurio

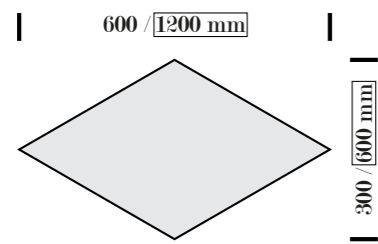
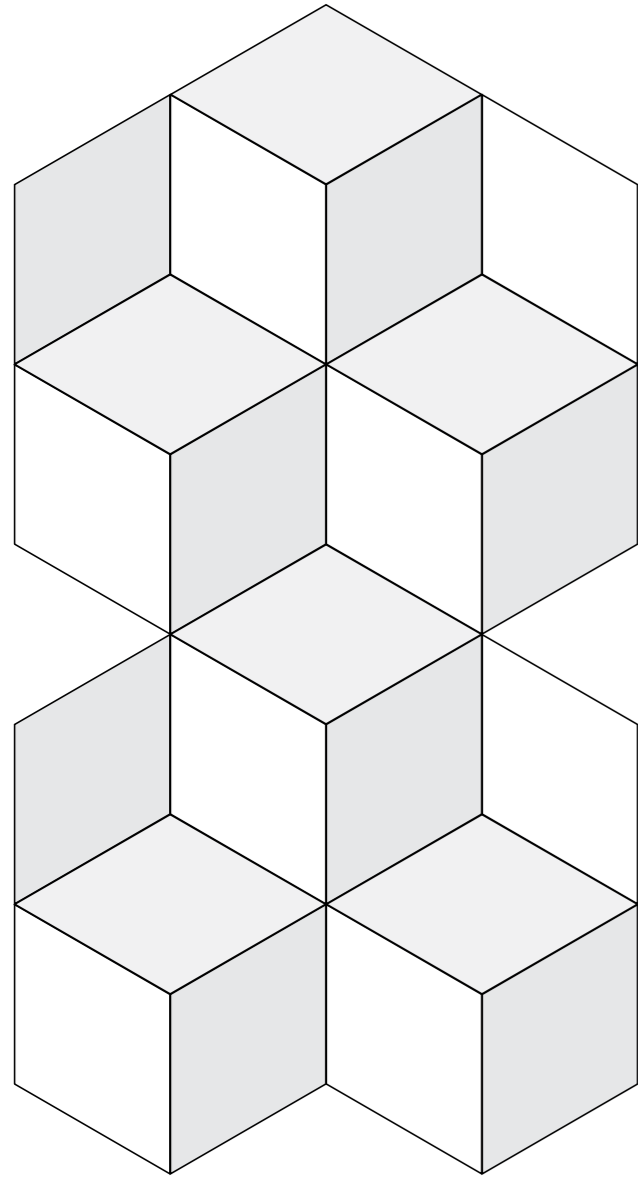

SOLID WOOD / MULTILAYER

# Diana

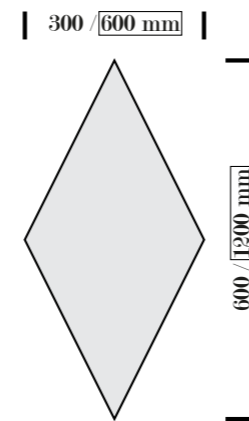
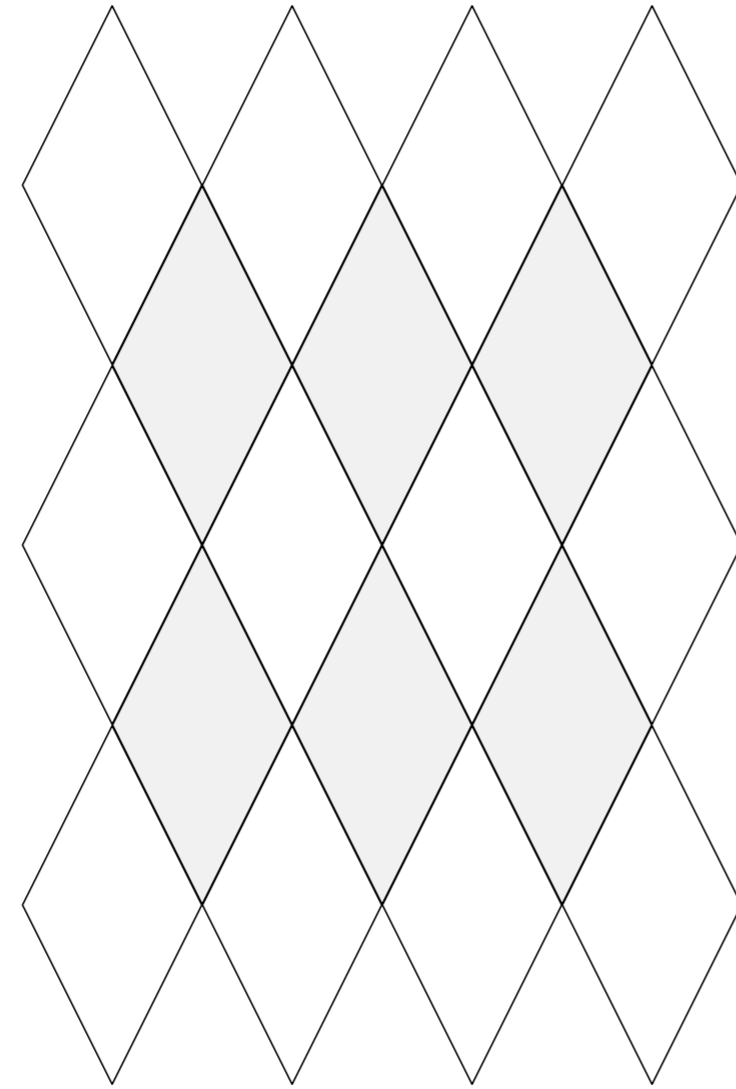

# Luna

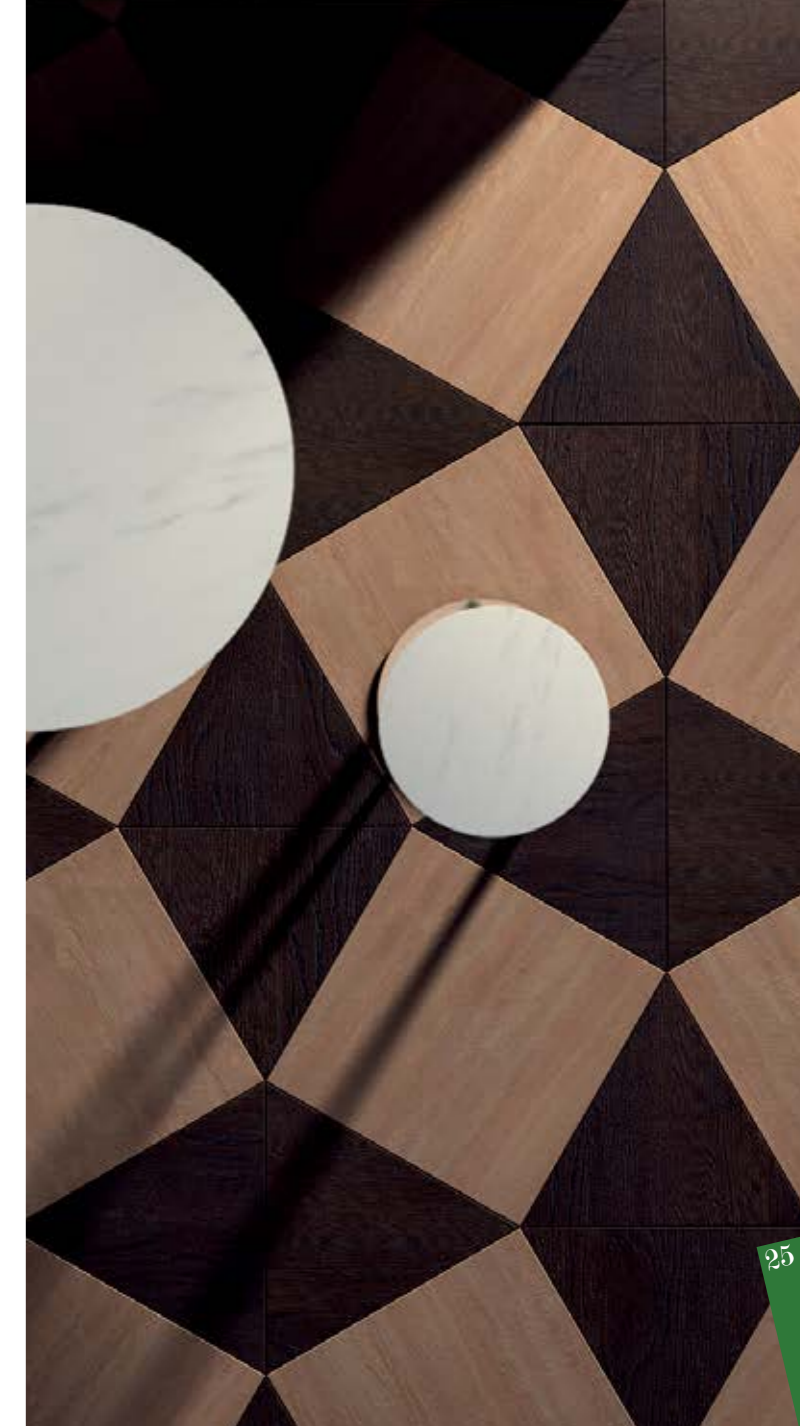
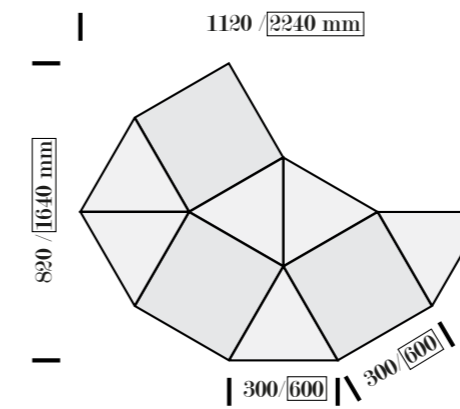
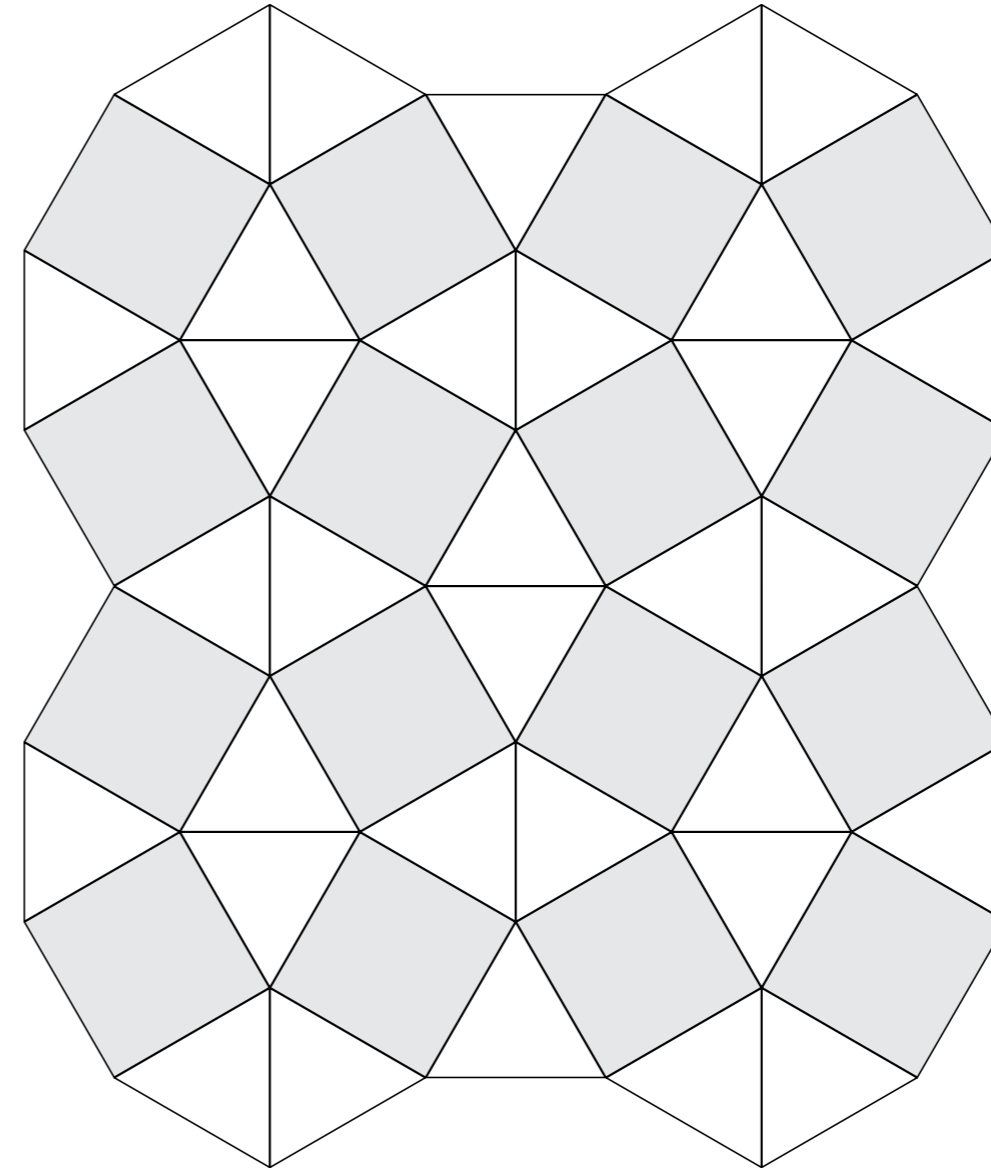

CREDITS

PROJECTS :

QUADROLEGNO DESIGN OFFICE — ITALY

MMAT ARCHITECTURE — ITALY

GRAPHIC PROJECT :

MMAT ARCHITECTURE — ITALY

SCRIPS :

ROBERTO TOMASINI — ITALY

MADE IN ITALY

QuadroLegno



Quadrolegno®

showroom: via Salimbene da Parma, 18  
26100 — Cremona ITALY

T: +39 0372 803302 - 3

F: +39 0372 803304

C.F. & P.IVA: 01453570192

[info@quadrolegno.it](mailto:info@quadrolegno.it)

[www.quadrolegno.it](http://www.quadrolegno.it)

